



allanblock.com

Commercial Installation Manual for



Allan Block® Retaining Walls

allanblock.com



About Us

Allan Block is a leading provider of patented retaining wall systems for large-scale commercial, industrial, roadway and residential projects.

For over twenty years, Allan Block has been helping landscape and construction professionals build better walls. With hundreds of millions of square feet of Allan Block in the ground, we can deliver the quality and performance you need. Our wide range of products allows you to be creative, efficient, and confident on every job.

Thank you for using Allan Block.

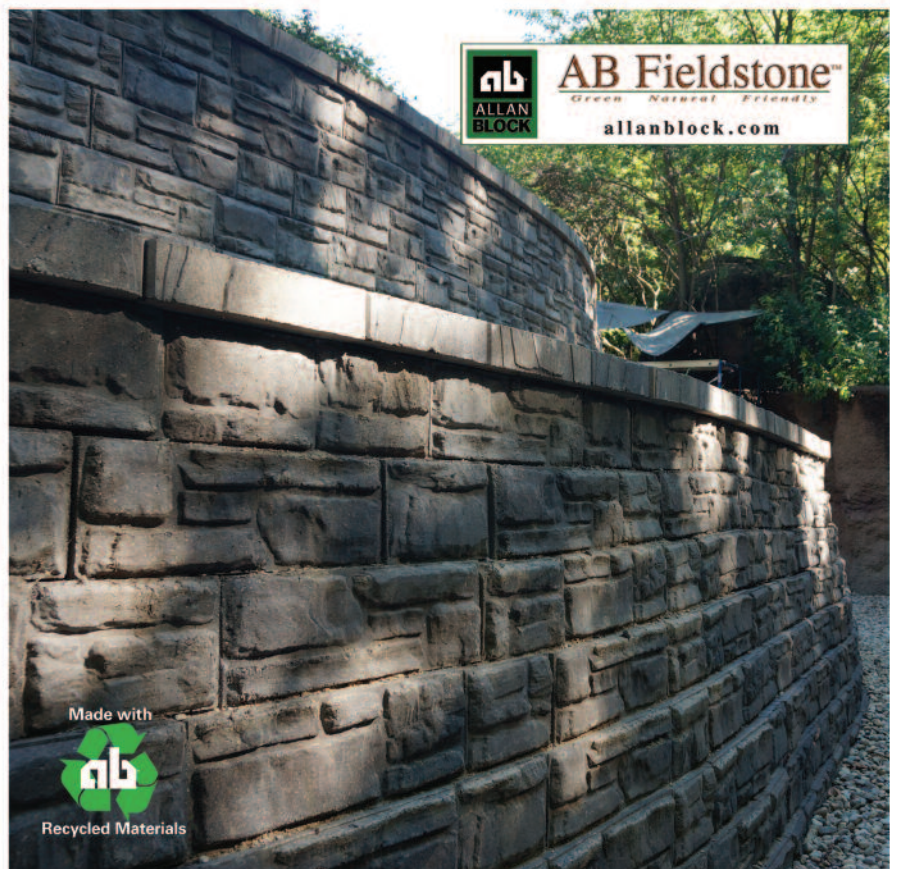

Table of Contents



allanblock.com

<u>Allan Block System</u>	8
Allan Block Products	9
Built-in Engineering	11
Gravity Walls	13
Reinforced Walls	15
Other Reinforcement Options	17
<u>Plan/Design</u>	18
Develop a Plan	19
Design Evaluation	22
<u>Build with AB and AB Europa</u>	24
Gravity Wall Construction	25
Reinforced Wall Construction	26
No-Fines Concrete Backfill & Installation	30
Working with Soils	32
Compaction	33
Water Management	34
<u>Build Patterned Walls with AB and AB Europa</u>	36
Wall Patterns	37
Patterned Wall Construction	38
Patterned Wall Construction Tips	40
<u>Build with AB Fieldstone</u>	42
Gravity Wall Construction	45
Reinforced Wall Construction	47
AB Fieldstone Construction Tips	49
<u>Construction Details with AB and AB Europa</u>	54
Finishing Walls	55
Curves	56
Curves with Geogrid	58
Corners	59
Corners with Geogrid	60
Stairs	61
Terraces	63
Design Details	65
Construction and Inspection Checklist	67
Material Estimate Worksheet	69
Geogrid and No-Fines Estimating Charts	72
<u>Specifications</u>	73
References	78
<u>Charts and Tables</u>	
Products	10
Standard Product Specifications	12
Maximum Wall Heights	13
Soils	19
Setback	21
Friction Angle and Soil Weight	32
Minimum Radius	49, 57
Geogrid and No-Fines Concrete	72



Creative Solutions

You can rely on quality Allan Block products and talented professionals to provide you creative solutions that work. Every day, on city streets, backyard landscapes and commercial properties, Allan Block delivers proven performance. Build your own creative solutions, build with Allan Block.

Attend an AB® Contractor Certification Training today to learn the proper techniques to ensure top quality retaining walls are built. Visit allanblock.com for the latest information as well as a complete schedule of upcoming training near you.

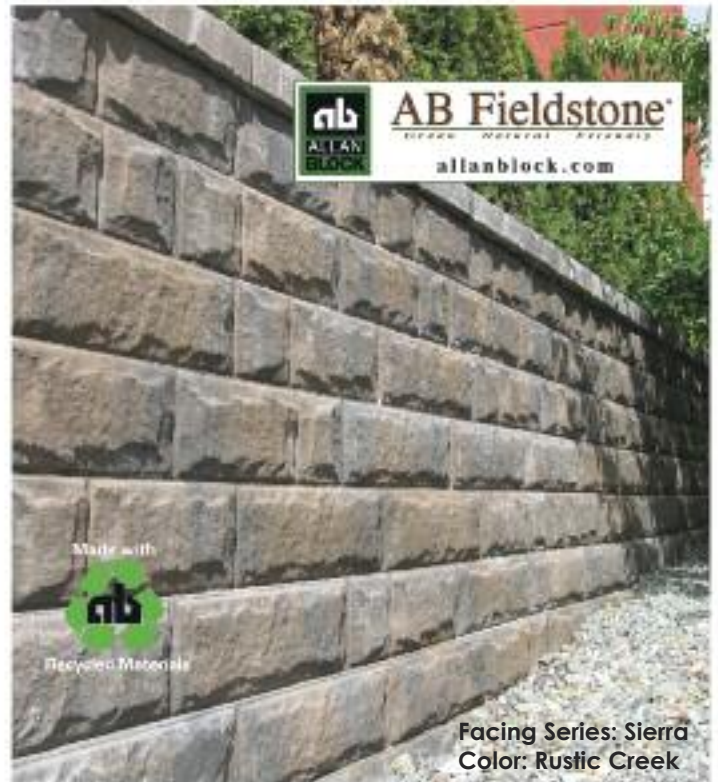



allanblock.com

Online Resources



- Product Information
- Technical Notes
- Construction Details
- Specifications
- Testing Reports
- CADD Details
- Installation Guides
- Design Software
- Estimating Software and Apps
- Photo and Video Library
- Case Studies/Project Profiles
- Multiple Languages
- Continuing Education Credits
- Training Information and Schedules
- Testing Information
- and much more!



Available at allanblock.com



Facing Series: Cascade
 Color: Rustic Creek



Facing Series: Colonial
 Color: Sandstone

See page 43 for
 detailed information
 on the AB Fieldstone
 Collection.





Facing Series: Heritage
Color: Black Hills



allanblock.com

Environmentally Conscious

Allan Block is on the leading edge of creating a manufacturing process that leaves very little waste and can use locally found recycled materials to produce their latest retaining wall system.

The AB Fieldstone Collection® is Allan Block's solution to a "Green/Eco-Friendly" retaining wall system while still maintaining the beautiful look of natural stone that is desired. This user-friendly two-piece system will revolutionize how retaining walls are made in the future.



Facing Series: Sierra
Color: Rustic Creek



Facing Series: Sierra
Color: Sandstone



SYSTEM



allanblock.com

Allan Block product and wall system information.

Allan Block Products	9
Built-in Engineering	11
Gravity Walls	13
Reinforced Walls	15
Other Reinforcement Options	17

A Complete Family of Wall Products

The Allan Block Collections give you a choice of styles to meet your site and design requirements. Use the basic gravity wall system for smaller wall projects. For taller wall projects use geogrid to reinforce the wall, or consider optional techniques using masonry, no-fines, rock bolts, soil nails, or earth anchors.

AB® Collection - Classic Cut Style



The **AB® Collection** has been a favorite of wall builders for years and offers the perfect blend of performance and style with maximum results.

AB Europa® Collection - Old World Antique



The **AB Europa® Collection** captures the hand-laid stone effect that brings old world charm and distinction to any project in beautiful marbled colors.

AB Fieldstone® Collection - Green, Natural, Friendly



The **AB Fieldstone® Collection** is a "Green/Eco-Friendly" retaining wall product that maintains the beautiful look and feel of natural stone. Installing and performing like our other Collections, AB Fieldstone truly is a friendly product.



allanblock.com

The Allan Block Collections offer a variety of sizes, weights, setbacks, and finishes to meet differing aesthetic and performance needs. Refer to the chart below or to our website - allanblock.com to help make the right choice for your project.

Table 1.1

Style & Performance		Name	Setback	Coverage	Weight	Approximate Dimensions
 AB[®] COLLECTION	AB Stones <i>Best Single Block Choice</i>	12°	1 sq ft. approx. 11 blk per m ²	75 lbs 34 kg	8 in. H x 12 in. D x 18 in. L 200mm H x 300mm D x 460mm L	
	AB Rocks	6°	1 sq ft. approx. 11 blk per m ²	75 lbs 34 kg	8 in. H x 12 in. D x 18 in. L 200mm H x 300mm D x 460mm L	
	AB Vertical	3°	1 sq ft. approx. 11 blk per m ²	75 lbs 34 kg	8 in. H x 12 in. D x 18 in. L 200mm H x 300mm D x 460mm L	
	AB Classic	6°	1 sq ft. approx. 11 blk per m ²	75 lbs 34 kg	8 in. H x 12 in. D x 18 in. L 200mm H x 300mm D x 460mm L	
	AB Jumbo Jr	6°	0.5 sq ft. approx. 22 blk per m ²	35 lbs 16 kg	8 in. H x 9.5 in. D x 9 in. L 200mm H x 240mm D x 230mm L	
	AB Lite Stone	6°	0.5 sq ft. approx. 22 blk per m ²	35 lbs 16 kg	4 in. H x 12 in. D x 18 in. L 100mm H x 300mm D x 460mm L	
	AB Junior Lite	6°	0.25 sq ft. approx. 44 blk per m ²	18 lbs 8 kg	4 in. H x 12 in. D x 9 in. L 100mm H x 300mm D x 230mm	
Old World Antique		Name	Setback	Coverage	Weight	Approximate Dimensions
 AB EUROPA[®] COLLECTION	AB Dover	6°	1 sq ft. approx. 12 blk per m ²	80 lbs 36 kg	8 in. H x 10.5 in. D x 18 in. L 200mm H x 265mm D x 460mm L	
	AB Palermo	6°	0.5 sq ft. approx. 22 blk per m ²	35 lbs 16 kg	8 in. H x 9.5 in. D x 9 in. L 200mm H x 240mm D x 230mm L	
	AB Barcelona	6°	0.5 sq ft. approx. 22 blk per m ²	40 lbs 18 kg	4 in. H x 10.5 in. D x 18 in. L 100mm H x 265mm D x 460mm L	
	AB Bordeaux	6°	0.25 sq ft. approx. 44 blk per m ²	20 lbs 9 kg	4 in. H x 10.5 in. D x 9 in. L 100mm H x 265mm D x 230mm L	
Green, Natural & Friendly		Name	Setback	Coverage	Weight	Approximate Dimensions
 AB FIELDSTONE[®] COLLECTION	812 facing unit with SAU	6°	0.7 sq ft. approx. 16 blk per m ²	60 lbs 30 kg	8 in. H x 13 in. D x 12 in. L 200mm H x 330mm D x 300mm L	
	812 facing unit with LAU	6°	0.7 sq ft. approx. 16 blk per m ²	90 lbs 40 kg	8 in. H x 23 in. D x 12 in. L 200mm H x 585mm D x 300mm L	
	824 facing unit with SAU	6°	1.3 sq ft. approx. 8 blk per m ²	125 lbs 55 kg	8 in. H x 13 in. D x 24 in. L 200mm H x 330mm D x 600mm L	
	824 facing unit with LAU	6°	1.3 sq ft. approx. 8 blk per m ²	185 lbs 85 kg	8 in. H x 23 in. D x 24 in. L 200mm H x 585mm D x 600mm L	
		SAU - short anchoring unit LAU - long anchoring unit				

Actual dimensions, weights and setbacks will vary by manufacturer. Check with your local Allan Block manufacturer for exact specifications and color availability. Caps and corner blocks are also available for each of the collections.

Patterned Walls

The design possibilities are endless. Use the blocks from the AB or AB Europa Collections individually or blend them together to create AB Ashlar or AB Abbey Blend patterned walls. The interlocking blocks easily fit together without any materials or tools.

AB Ashlar Blend™
from the AB Collection



AB Abbey Blend™
from the AB Europa Collection



The Allan Block System - Engineered For Simplicity

Allan Block's built-in features make retaining walls easy to engineer and simple to build. These simple engineering features make the Allan Block Collections the most efficient and reliable products on the market.

Mortarless Construction

Mortarless technology works. Building "flexible" structures with interlocking dry-stacked materials provides superior performance over rigid construction techniques. Add the benefits inherent in a mortarless system - site adaptability, installation by general laborers, lower cost - and you have what we call the Allan Block Advantage.



Mortarless construction has been used for centuries.

Built-In Engineering

Built-In Interlock

Every Allan Block is firmly locked in place by the patented lip and notch configuration. No pins, no mortar, no fancy connectors.

Built-In Setback

The raised lip automatically establishes the proper setback. Choose from 12°, 6°, or 3° systems.

Built-In Drainage

The hollow-core design combines with mortarless construction to allow water to drain freely from behind the wall. Incidental water moves easily through a vertical drain that is formed by the layer of wall rock placed behind the block and in the block cores. The dry-stack construction technique allows the incidental water to escape by flowing around the blocks and out the wall face. This built-in drainage helps to eliminate water pressure. Please note that this area is not to be used as a primary water management element.

Built-In Interlock



Built-In Setback

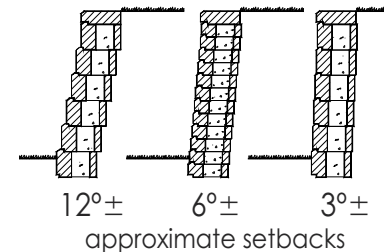

Built-In Drainage

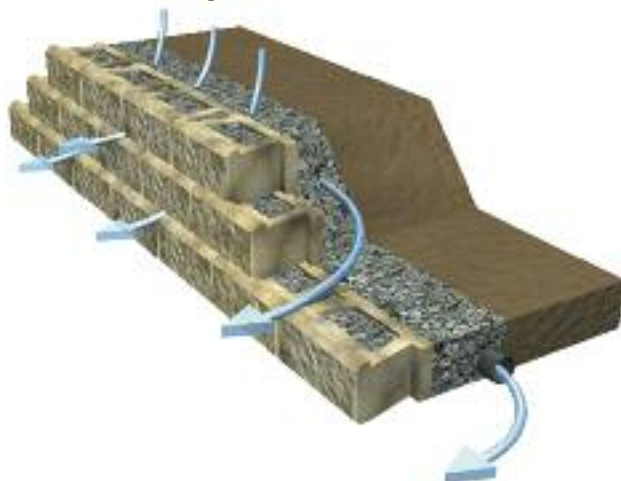



allanblock.com

Hollow-Core System

Allan Block's exclusive hollow-core product design provides many benefits over solid systems.

- Superior drainage.
- Faster drying in wet environments.
- Better resistance to freeze-thaw cycles.
- Improved efflorescence control.
- Easier handling, faster installation, lower labor costs.
- Block-to-block interlock created from wall rock in the blocks.
- Lower production and freight costs.



Table 1.2

Standard Product Specifications

Compressive Strength	3000 psi	20.67 MPa
Absorption <i>Northern Climates</i>	7.5 lb/ft ³	120 kg/m ³
Absorption <i>Southern Climates</i>	10 lb/ft ³	160 kg/m ³
Unit Density - Hollow	125 lb/ft ³	2002 kg/m ³
Unit Shear Strength	645 lb/ft	9406 N/m

Reference ASTM 1372



Gravity Walls

A retaining wall that relies solely on its own weight to stand up is called a gravity wall. Allan Block combines the basic engineering principles of setback, leverage and total unit mass with simple mechanics to make highly stable gravity walls.

Setback & Sliding Wedge

Every retaining wall supports a "wedge" of soil. The wedge is defined as the soil which extends beyond the failure plane of the soil type present at the wall site, and can be calculated once the soil friction angle is known. As the setback of the wall increases, the size of the sliding wedge is reduced. This reduction lowers the pressure on the retaining wall.

See references 1, 8, 18

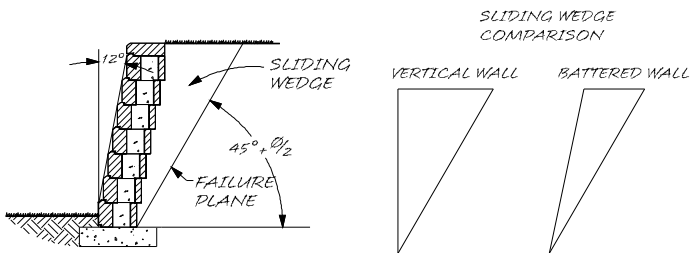

Leverage and Total Unit Mass

As the setback of a gravity wall increases, the leverage from course to course increases. This added leverage allows you to build taller walls before reinforcement is needed.

With the hollow core design, Allan Block comes to the job site weighing less than solid, heavy block. Once the cores are filled, the Allan Block units develop the same unit mass as solid blocks. This mass combines with the setback to determine the maximum gravity wall heights.

See Table 1.3.

See reference 1

Allan Block's 12° (Ref) system can achieve wall heights up to 5.5 ft. (1.7 m) without reinforcement in good soils with a level slope above.



Table 1.3

Gravity Wall Heights

Use the gravity wall chart to find the maximum height that can be built before reinforcement is required.

The gravity wall heights shown do not account for seismic loading. Check with a local engineer for assistance if you are in a seismic area.

See reference 1, 7

Maximum Wall Heights - AB Gravity Walls							
Condition above retaining wall	Soil Type	Friction Angle	12° (Ref) AB Stones only of AB Collection	6° (Ref) AB and Europa Collections	6° (Ref) AB Fieldstone Short Anchoring Unit (SAU)	6° (Ref) AB Fieldstone Long Anchoring Unit (LAU)	3° (Ref) AB Vertical only of AB Collection
Level	Clay	27°	3 ft. 6 in. 1.0 m	3 ft. 2 in. 0.9 m	3 ft. 7 in. 1.1 m	5 ft. 10 in. 1.8 m	2 ft. 11 in. 0.9 m
	Silty Sand	32°	5 ft. 4 in. 1.6 m	4 ft. 7 in. 1.4 m	5.0 ft. 1.5 m	8 ft. 6 in. 2.6 m	3 ft. 9 in. 1.1 m
	Sand/Gravel	36°	5 ft. 10 in. 1.8 m	5 ft. 2 in. 1.6 m	5 ft. 8 in. 1.7 m	9 ft. 8 in. 3.0 m	4 ft. 3 in. 1.3 m
Surcharge* 100 psf (4.7 kPa)	Clay	27°	1 ft. 8 in. 0.5 m	1 ft. 4 in. 0.4 m	1 ft. 8 in. 0.5 m	4.0 ft. 1.2 m	1 ft. 1 in. 0.3 m
	Silty Sand	32°	3 ft. 10 in. 1.2 m	3 ft. 1 in. 0.9 m	3 ft. 7 in. 1.1 m	7.0 ft. 2.1 m	2 ft. 4 in. 0.7 m
	Sand/Gravel	36°	4 ft. 6 in. 1.4 m	3 ft. 6 in. 1.0 m	4 ft. 2 in. 1.3 m	8.0 ft. 2.4 m	2 ft. 6 in. 0.8 m
Slope 3:1	Clay	27°	2 ft. 8 in. 0.8 m	2 ft. 4 in. 0.7 m	2 ft. 8 in. 0.8 m	4 ft. 4 in. 1.3 m	2 ft. 1 in. 0.6 m
	Silty Sand	32°	4 ft. 8 in. 1.4 m	4 ft. 1 in. 1.2 m	4 ft. 4 in. 1.3 m	7 ft. 4 in. 2.3 m	3 ft. 2 in. 0.9 m
	Sand/Gravel	36°	5 ft. 10 in. 1.8 m	4 ft. 7 in. 1.4 m	5 ft. 1 in. 1.5 m	8 ft. 7 in. 2.6 m	3 ft. 9 in. 1.1 m

Table 1.3 is based on Clay soil having an internal friction angle of 27° (Ref) or better and a Sandy soil having an internal friction angle of 32° (Ref) or better and a Sand/Gravel soils having an internal friction angle of 36° (Ref) or better. All heights based on exposed wall heights and include a cap block. The gravity wall heights shown above do not account for seismic loading. Check with a local engineer for assistance if you are in a seismic area. Final designs for construction purposes must be performed by a local registered Professional Engineer, using the actual conditions of the proposed site. *The Surcharge loading category above assumes a solid surface such as concrete, asphalt or pavers having a suitable supporting subgrade.



allanblock.com

Sample Calculation

Analyze a gravity wall with the following site conditions:

Soil Type = Mixed Silts

$(\phi) = 30^\circ$

Wall Height (H) = 3.44 ft (1.05 m)

Batter = 12°

Depth of Wall (d) = 0.97 ft (0.3 m)

Bearing Capacity (σ_s) = 3000 lb/ft² (143,640 Pa)

Wall Density (γ_w) = 130 lb/ft³ (2,061 kg/m³)

Soil Density (γ_s) = 120 lb/ft³ (1,923 kg/m³)

Factored Friction Angle (ϕ_w) = 0.66ϕ

Slope Above Wall (i) = 0 Surcharge = None

Sliding Resistance

F_A = Active force on wall = $0.5 (\gamma_s) (K_A) H^2 = 156 \text{ lb/ft (2,295 N/m)}$

K_A = Active pressure coefficient

$$K_A = \left[\frac{\text{CSC}(\beta) \sin(\beta - \phi)}{(\sin(\beta + \phi_w))^{1/2} + \left(\frac{\sin(\phi + \phi_w) \sin(\phi - i)}{\sin(\beta - i)} \right)^{1/2}} \right]^2 = 0.2197$$

W = Total weight of wall = $\gamma_w (H) (d) = 434 \text{ lb/ft (6,639 N/m)}$

F_V = Vertical force on wall from retained soils = $F_A \sin(\phi_w) = 53 \text{ lb/ft (785 N/m)}$

F_H = Horizontal force on wall from retained soils = $F_A \cos(\phi_w) = 147 \text{ lb/ft (2,157 N/m)}$

F_R = Force resisting sliding = $(W + F_V) \tan \phi = 281 \text{ lb/ft (4,130 N/m)}$

Safety factor against sliding: $\text{SFS} = \frac{F_R}{F_H} = \frac{281 \text{ lb/ft (4,130 N/m)}}{147 \text{ lb/ft (2,157 N/m)}} = 1.91 \geq 1.5 \text{ OK}$

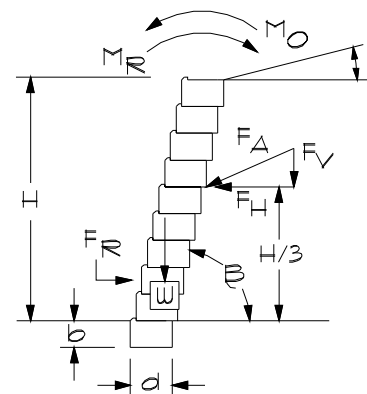

Overturning Resistance

M_O = Overturning moment = $F_H (0.33) H = 168 \text{ ft. lb/ft (754 N-m/m)}$

M_R = Moment resisting overturning = $(W) [d/2 + 0.5 (H) \tan(90^\circ - \beta)]$

+ $(F_V) [d + (0.33) (H) \tan(90^\circ - \beta)] = 436 \text{ ft. lb/ft (1,945 N-m/m)}$

Safety factor against overturning:

$$\text{SFO} = \frac{M_R}{M_O} = \frac{436 \text{ ft. lb/ft (1,945 N-m/m)}}{168 \text{ ft. lb/ft (754 N-m/m)}} = 2.6 \geq 1.5 \text{ OK}$$

Bearing Capacity

σ_w = Pressure exerted on soil below base block = $(W + F_V) / d = 487 \text{ lb/ft}^2 (23,847 \text{ Pa})$

$\sigma_s = 3000 \text{ lb/ft}^2 (143,640 \text{ Pa})$

Safety factor against bearing failure:

$$\text{FSB} = \frac{\sigma_s}{\sigma_w} = \frac{3,000 \text{ lb/ft}^2 (143,640 \text{ Pa})}{487 \text{ lb/ft}^2 (23,847 \text{ Pa})} = 6.16 \geq 2.0 \text{ OK}$$

See the Allan Block Engineering Manual for more information.

Gravity Wall Analysis

Before you analyze any retaining wall make sure you have an accurate picture of the job site conditions. Every retaining wall must be engineered to withstand the pressure from the soils and other loads behind and above them. Standard gravity wall analysis considers sliding, bearing and overturning forces. On sites with slopes or surcharges, a global stability check will also be necessary.

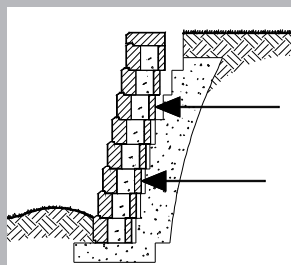

Sliding

Ability of the structure to overcome the horizontal force applied to the wall.

Factor of safety = 1.5

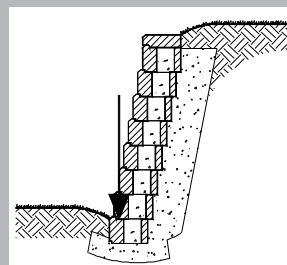

Bearing Capacity

Ability of the underlying soil to support the weight of the structure.

Factor of safety = 2.0

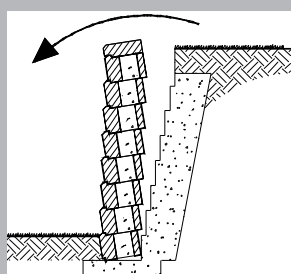

Overturning

Ability of the structure to overcome the overturning moment created by the rotational forces applied to the wall.

Factor of safety = 1.5

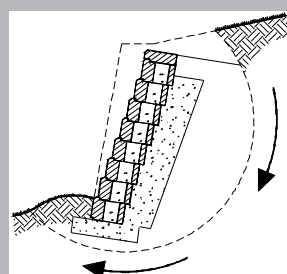

Global Stability

Ability of the internal strength of the soil to support the complete soil mass. Contact local design specialist for help in evaluating your site.

See reference 1

OTHER CONSIDERATIONS: • Slopes • Surcharges • Terraces

Reinforced Soil Walls

Concept

When wall heights exceed those listed in the gravity wall chart on page 13, geogrid can be added to provide a stable wall condition. Layers of geogrid inserted between the blocks and extending behind the wall interlock with the surrounding soil to create a cohesive soil mass. This mass uses its own weight and internal shear strength to resist both the sliding and the overturning pressures from the soil being retained. The wall rock in the Allan Block cores provide a positive connection between the layers of geogrid and the Allan Block wall, locking the two systems together. The reinforced soil mass becomes the structure and the Allan Block wall becomes the facing. The specific location and embedment length of the grid layers depends upon the site conditions, wall heights and Long-Term Allowable Design Strength of the grid being used. See the approved plans for exact geogrid locations or consult with a local engineer.



The Great Wall of China, dating back some 2,200 years, was built as a double sided retaining wall. The soil between the two walls was a mixture of clay and gravel reinforced with Tamarisk branches. Allan Block retaining walls employ "old technology with new materials."

Geogrids

Geogrids are flexible, synthetic meshes which are manufactured specifically for slope stabilization and earth retention. These "grids" are available in a variety of materials, sizes and strengths. They can be made of high tensile strength plastics or woven polyester yarns and are typically packaged at the factory in rolls. The grids are rated by Long-Term Allowable Design Strength (LTADS) with values ranging from 500 to 4,000 pounds per linear foot (7.3 kN/m to 58.4 kN/m).

See reference 1



Positive Interlock

Allan Block's gravel filled hollow core provides a multi-point interlock with the grid. As wall heights increase, our exclusive "Rock-Lock" connection, combined with the weight of the Allan Block units, provides the best **block-to-grid** interlock of any system on the market. See the tech sheets on connection testing or the *Seismic Testing Executive Summary* for testing results on the "Rock-Lock" connection. Connection strength testing has been done with our grid manufacturers for results see the AB Spec Book or AB Engineering Manual.

See reference 1, 2, 3, 13

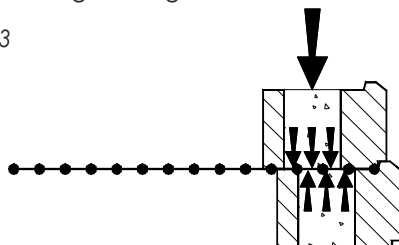



allanblock.com

Analysis

External Stability

External stability exists when the entire wall system - the Allan Block facing units and the reinforced soil mass - act as a coherent structure to satisfy standard gravity wall analysis. Proper wall design must satisfy all four of the following considerations.

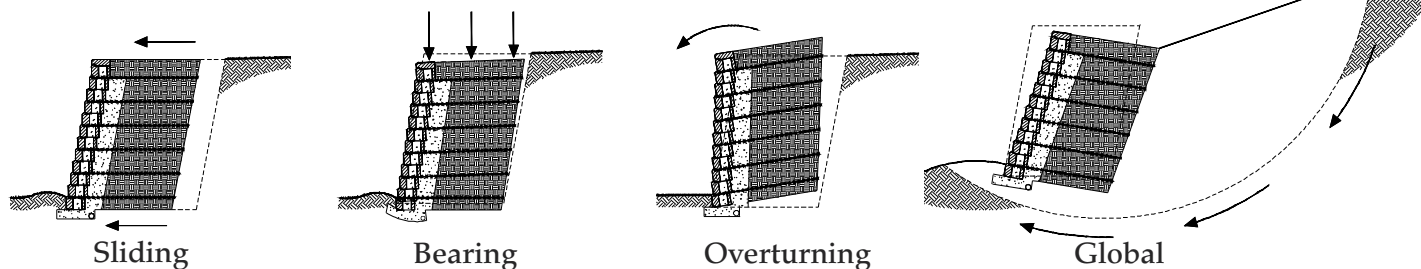

Internal Stability

Internal stability is the ability of the reinforcement combined with the internal strength of the soil to hold the soil mass together and work as a single unit.

Internal Compound Stability

Slip plane that runs through the retained and reinforced soil and wall facing.

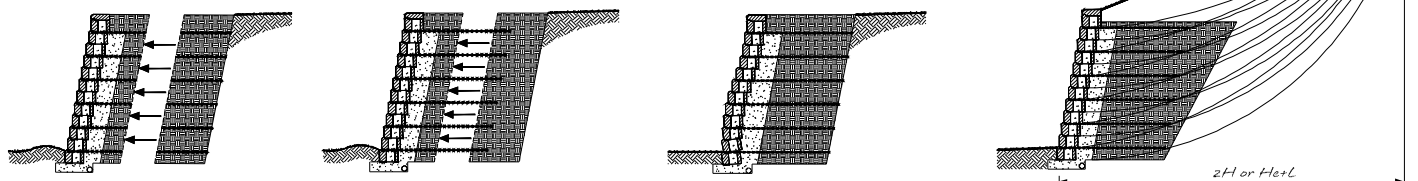

Grid Rupture

Rupture occurs when excessive forces exceed the ultimate tensile strength of the geogrid.

Increase grid strength or the number of grid layers

Pullout

Pullout results when grid layers are not embedded a sufficient distance beyond the failure plane.

Increase embedment length

Bulging

Bulging occurs when horizontal forces between the geogrid layers causes localized rotation of the wall.

Increase number of grid layers

Internal Compound

Internal Compound instability occurs when a slip arc passes through retained soil, reinforced soil, and facing.

Increase length, strength, or decrease spacing of grid, use select infill material

See reference 1, 12, 17

Design Considerations

- **Grid strength** Select the right strength grid for the job. Choose LTADS grids from 500 lb/ft to 4000 lb/ft (7.3 kN/m to 58.4 kN/m).
- **Embedment length** Grid length must extend far enough behind the wall to create a sufficient reinforced gravity mass. Typically a minimum of 60% of total wall height.
- **Number of layers** Install enough layers to adequately increase the internal strength of the soil mass and handle all applied loads.
- **Spacing between layers** Grid layers must be correctly spaced to distribute internal forces. Typically spaced on 16 in. (405 mm) centers.
- **Connection strength** Block and geogrid must work together to resist internal forces.

AB Geogrid Wall Typical Section

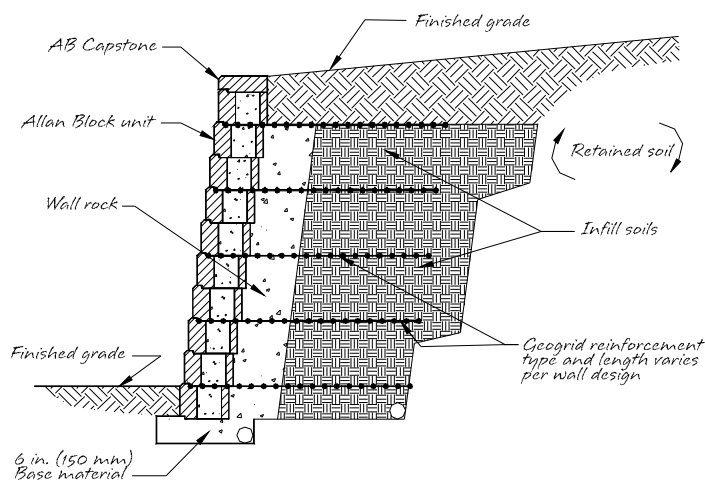

allanblock.com

Other Reinforcement Options

Masonry Reinforcement

Allan Block retaining walls can be reinforced with the same proven techniques used for conventional masonry walls. Allan Block masonry walls are useful on sites where geogrids are not feasible or cost effective because they rely on a reinforced footing and vertical pilasters to counteract lateral earth pressures. These walls combine the mortarless stability of an Allan Block wall with the tensile strength of the steel rods in pilasters and the stability of the footing. The design and construction of these walls meet all building code requirements, while factoring in the benefit of an inclined Allan Block wall. The specific design requirements depend on site and soil conditions, and wall heights.

See reference 11

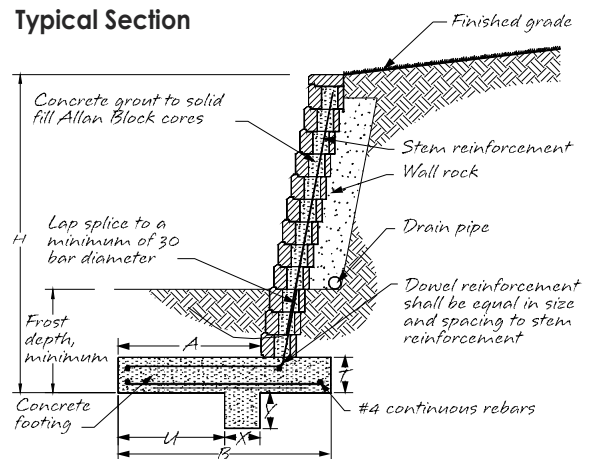

When considering special applications, unusual job sites, or unique reinforcement requirements, contact the Allan Block Corporation for engineering and design support.

The Allan Block Engineering Department provides assistance to engineering and design professionals worldwide. For additional information and case studies call 800-899-5309.

Other System Options

In addition to basic masonry wall systems, Allan Block can accommodate special reinforcement systems such as no-fines concrete, rock bolts, earth anchors and soil nailing.

See page 30-31 for more information on No-Fines Concrete and installation information.

Earth Anchor

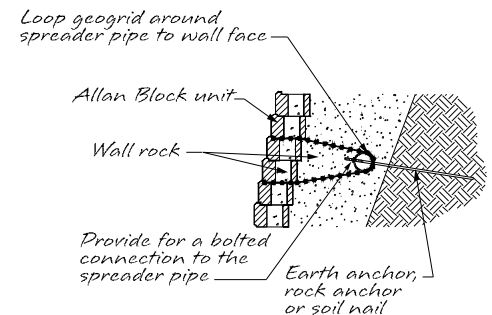

Soil Nailing

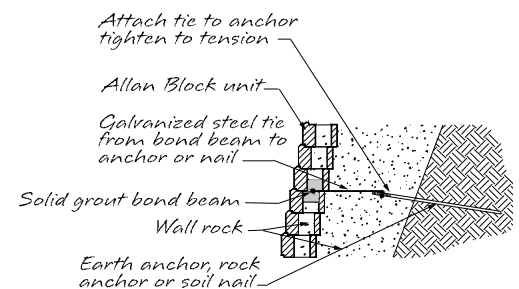

No-Fines Concrete (NFC Backfill)

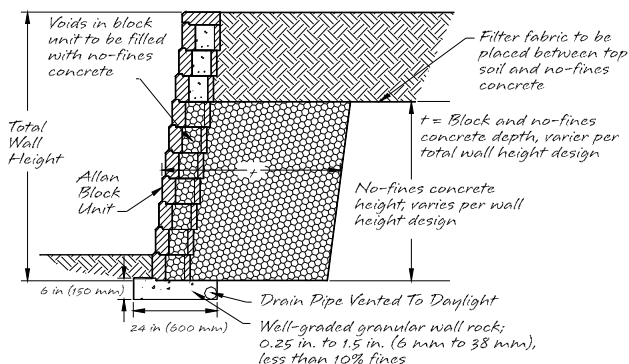

PLAN / DESIGN



allanblock.com

Plan and Design an Allan Block project.

Develop a Plan	19
Design Evaluation	22

Plan

Develop an accurate understanding of the job site before beginning any design, engineering, or construction on a project.

Site Geometry

Develop an accurate PLAN of existing physical features. Observe the soil type and condition, site geometry at the wall location and immediate surroundings. Note the natural drainage patterns. Identify all physical features surrounding the proposed wall location. Note key elevations, lot lines, utilities, structures, vegetation, etc. Conditions above and behind the wall will determine how high the wall can go before reinforcement is needed.



Note the site geometry above and below the proposed wall location.

Soils

- Soil conditions behind and below each retaining wall have a direct effect on the strength needed in that retaining wall. The pressure from behind the wall will vary substantially depending on the soil type. In general, a wall built in clay soils will require more reinforcement than a wall of the same height built in free draining sand or gravel soils.
- Check the soil type and conditions at the base of each wall for adequate bearing pressure. The soil below a wall needs to be strong enough to support the weight of the wall resting on it. When moisture is present, extra precautions may be required to provide a stable base.
- If the soils at the base of the wall have been disturbed - i.e. excavated and replaced - it is imperative that these soils are properly compacted before construction begins. It may be necessary to remove poorly compacted or soft, wet organic soils at the base and replace them with stable, well-compacted soils prior to wall construction.

See page 32 & 33.

Table 2.1

Soils			
Soil Type	Friction Angle (Ref)	Bearing Capacity	Equivalent Fluid Pressure
Clay	27°	2,500 lb/ft ²	50 lb/ft ³
		119.700kPa	7.9kN/m ³
Mixed Soils	32°	3,500 lb/ft ²	35 lb/ft ³
		167.580kPa	5.5kN/m ³
Sand/Gravel	36°	4,000 lb/ft ²	30 lb/ft ³
		191.520kPa	4.7kN/m ³

Use the soil classification chart above to identify the basic properties of the soil at the site. These soil properties are approximate. For a thorough soil analysis, have a qualified geotechnical engineer conduct a site inspection.

Water Management

Make a careful observation of the general drainage patterns at the site. Note the amount of area above the wall which will shed surface runoff toward the wall. Note the type of surface (i.e., paved surfaces, sodded areas, etc.) to determine the water flow and volume. Note any concentrated sources of water flow such as runoff from parking lots, roof drains and scuppers, drainage swales, creek beds, ground water, etc. See page 34 & 35.

Grading

Develop a grading plan that routes water around the walls as much as the site will allow. Provide swales above and below the wall as required to accommodate water movement. Divert sources of concentrated water flow from the wall. Retaining wall designs must prevent the pooling of water above or below the wall.

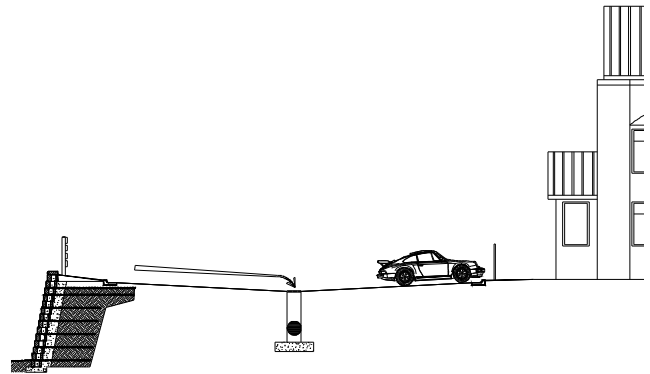

Drainage

Proper drainage planning considers water flow and volume *above, below, and behind* the retaining wall.

- Most Allan Block gravity walls (lower unreinforced walls) will drain adequately on their own.
- If a large area sheds water to the wall (i.e., parking lot), added drainage will be necessary.
- Concentrated sources of water must be planned for and managed.
- Reinforced walls will need added drainage for the backfill zone and the wall base.
- Major wall structures, roadway and municipal projects, and walls built in extreme rainfall or wet environments will need a thorough hydrology analysis prior to construction.



Surcharges

Any added weight above the wall is called a "surcharge". Parking lots, swimming pools, and driveways are common surcharges. Light duty surcharges are designed at 100 psf (4.7 kPa). Heavier commercial surcharges (like trucks), run 250 psf (12 kPa) and up. More concentrated line loads may also be a factor (such as building foundations). Engineering is required in each situation.

See reference 1

Surcharges

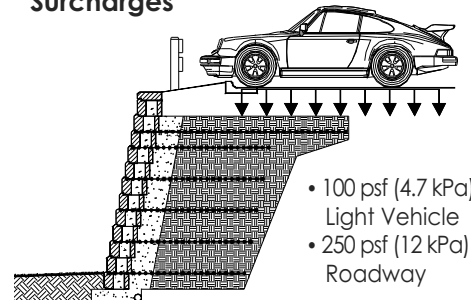

Slopes

Slopes are measured "run to rise". A three-to-one slope goes back 3 and up 1.

Slopes Above

Slopes above the wall add more pressure and will require more mass to resist movement. Engineering is required.

Slopes Below

Slopes below the wall may create an unstable foundation. Check with local building codes for length of bench that may be required. Engineering is required.

Slopes Above

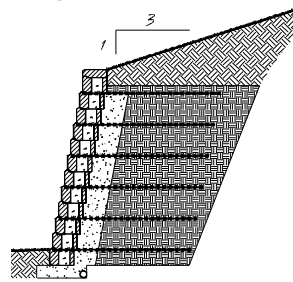

Slopes Below

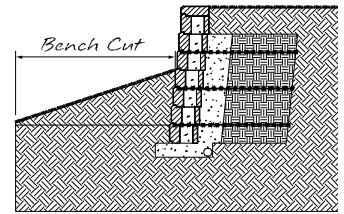

Setback

The amount the wall leans into the hill is called "setback". AB units come in multiple setbacks. Bigger setbacks provide better leverage and require less reinforcement. For taller walls use a story pole and level to check for proper setback. Setbacks increase when walls are built with radii. Comply with construction tolerances which are found in the **AB Spec Book** or approved construction plans.

Setback

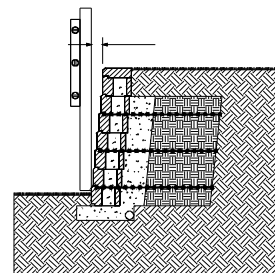

Note: Walls designed with a 12° (Ref) setback require more space than 6° (Ref) or 3° (Ref) systems, but will be more stable. You may give up ground, but the final factors of safety are higher.

Table 2.2

AB Setback Chart				
Setback	Wall Height			
	4 ft 1.2 m	6 ft 1.8 m	8 ft 2.4 m	10 ft 3.0 m
AB Stones only of the AB Collection	10.0 in 255 mm	15.0 in 380 mm	20.0 in 510 mm	25.0 in 635 mm
AB, AB Europa (excluding AB Stones & AB Vertical) and AB Fieldstone Collection	5.0 in 125 mm	7.50 in 190 mm	10.0 in 255 mm	12.5 in 320 mm
AB Vertical only of the AB Collection	2.5 in 65 mm	3.75 in 95 mm	5.0 in 125 mm	6.25 in 160 mm

All values are provided for reference only.

Global Stability

Global stability is an engineering analysis of the overall balance of a slope or hillside. Walls built on hillsides may affect this balance and stability. Cuts into a hillside will steepen the effective slope and shift the balance of the hill, thereby reducing stability. Walls built on top of slopes have the same effect. Engineering is required.

What to consider when assessing global stability:

- Surcharges / Terraced Walls
- Slopes
- Soil Properties
- Water

Global Stability

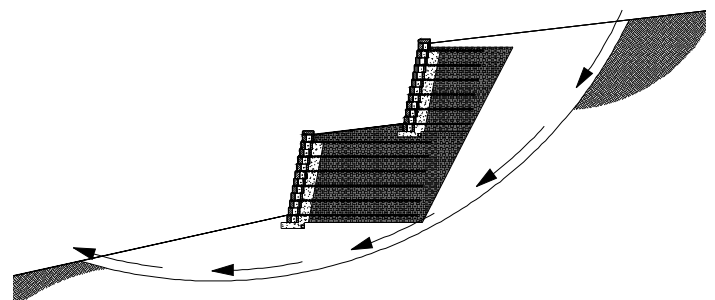

See reference 1, 18

Design



allanblock.com

PLAN/DESIGN

The design process for a segmental retaining wall typically has a Wall Design Engineer or Site Civil Engineer responsible for the wall design envelope. Geotechnical engineers should be hired to evaluate the overall stability of the site. For information into the basic concepts behind an Allan Block retaining wall design see Design Methods section of the AB Spec Book and Best Practices for SRW walls.

Proper retaining wall design requires evaluation of the following:

1. Select the wall location

- Minimize soil excavation and backfill.
- Optimize grading and drainage patterns.
- Consider existing site features.

2. Determine wall height and geometry

- Calculate the wall height at its tallest position.
- Identify slopes above and below the wall.
- Evaluate surcharges from vehicular or construction traffic.
- Select the appropriate wall batter or setback.

3. Evaluate structural requirements

- Check the gravity wall table on page 13 for reinforcement requirements.
- If geogrid is required, see pages 71-72 for approximate grid length.
- For projects that fall beyond the scope of the tables in this manual, refer to the *Allan Block Engineering Manual* and contact a qualified engineer.

4. Calculate the total wall structure

- Use Table 2.2 to calculate the total wall setback.
- Add the required grid lengths to determine total wall envelope.
- Cross check the total wall envelope with available space at wall site.

Note: For more information see the Checklist in the AB Spec Book.

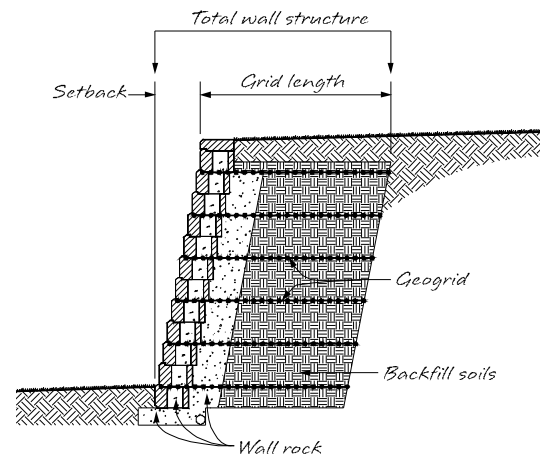
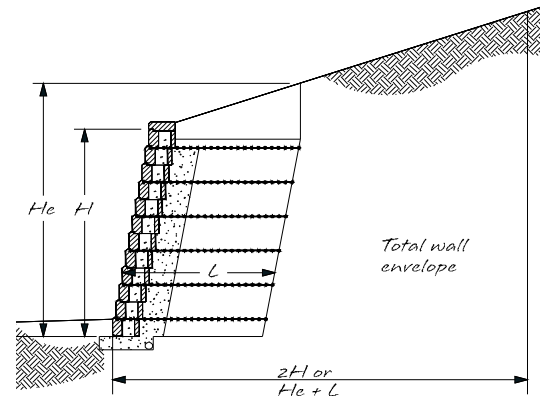

Material and Site Checklist Prior to Construction

Building a reinforced retaining wall requires advanced planning and careful layout at the job site.

Check Your Materials

- Cross check the block delivered for color, style and setback, and confirm it matches the AB unit specified on the approved plans.
- Cross check the geogrid delivered for strength, weight, roll size, strength direction and manufacturer, and confirm it matches the grid specified on the engineered plans.

Delivery and Storage

- Lay out a storage area for the block, geogrid reinforcement, and wall rock. Store blocks on wood pallets and keep the geogrid dry, covered and clean.
- Protect the materials from damage or from coming in contact with mud, wet concrete, and other contaminating materials. Damaged material should not be incorporated in the project.



Wall Rock

The proper placement of the wall rock serves several purposes:

- Locks the block and grid together to form a "Rock-Lock" connection.
- Increases the overall weight of each AB Unit, increasing structural stability.
- Facilitates the compaction process in and around the blocks.
- Prevents settlement directly behind the block, which minimizes additional forces on the grid.



- Wall Rock can be used for the base material, within the AB Block cavities and behind the block.
- Wall Rock must be compactible aggregate ranging in size from 0.25 in. to 1.5 in. (6 mm - 38 mm) with no more than 10% passing the #200 sieve with a minimum density of 120 lbs/ft³ (1,923 kg/m³). There needs to be a balanced mix of the sizes to achieve good compaction.

Backfill Soils

- On-site soils can be used for backfill around the geogrid reinforcement only if they meet or exceed the design specifications in the approved plans.
- Heavy expansive clays or organic soils shall not be used in the reinforced zone.
- Where additional fill is required, the contractor shall submit a sample to the wall design engineer or the on-site soils engineer for compliance with the approved plans.

Foundation Soil Preparation

- Foundation soil shall be excavated as dimensioned on the plans and compacted to a minimum of 95% of Standard Proctor prior to placement of the base material.
- Foundation soil shall be examined by the on-site soils engineer to ensure that the actual foundation soil strength meets or exceeds assumed design strength. Soil not meeting the required properties shall be removed and replaced with acceptable material.

Geogrid Layout

- The geogrid reinforcement design will determine the depth of the reinforced zone and the excavation required. Before construction begins, verify top of wall (TW) and bottom of wall (BW) locations. Check for buried utilities and other obstructions in the reinforced zone.

Refer to the AB Engineering Manual, Best Practices for SRW Walls, AB Spec Book, AB Seismic Executive Summary, and the AB Walls Software for more detailed information. For design assistance contact the AB Engineering Department or go to allanblock.com.

Wall Elevation - to identify grid locations

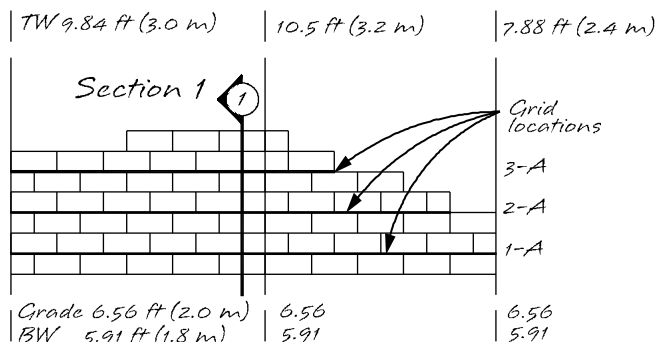

ELEVATION

Wall Cross Section

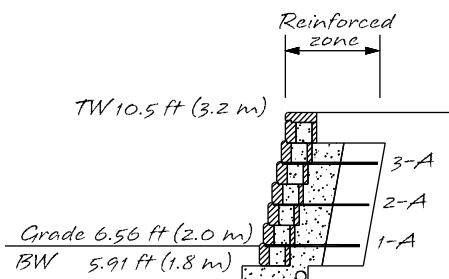

Section 1

BUILD



allanblock.com

Installation details for Gravity or Reinforced retaining walls
for Allan Block's AB and AB Europa Collection.

Gravity Wall Construction	25
Reinforced Wall Construction	26
No-Fines Concrete Backfill	30
Working with Soils	32
Compaction	33
Water Management	34

Gravity Wall Construction

Step 1: Site Prep and Excavation

- Remove surface vegetation and organic soils.
- Per the approved plan, excavate base trench a minimum of 24 in. (610 mm) wide and 12 in. (300 mm) deep.*
- Remove unsuitable soils and replace with compactible materials.
- Buried block should be a minimum of 6 in. (150 mm). Check plans to see how much buried block is required.
- Compact and level trench.

Step 2: Install Base Material

- Per the approved plans, place a minimum of 6 in. (150 mm) of wall rock in the base trench and rake smooth.*
- Compact and level base material.
- Site Soils Engineer should verify that a proper base is established.

Step 3: Install Base Course

- **Begin at the lowest wall elevation.** Place all units top side up with the raised front lip facing up and in the center of the base material. Check and adjust for level and alignment of each unit.
- Drain pipe is required for walls over 4 ft. (1.2 m) tall or are constructed in silty or clay soils. See approved plans for location and specifications. Refer to page 65 for details on an alternate drain location.

Step 4: Install Wall Rock and Backfill Materials

- Fill the hollow cores and a minimum of 12 in. (300 mm) behind the wall with wall rock.
- Use approved soils to backfill behind the wall rock and in front of the base course.
- Use a plate compactor to consolidate the area behind the block.
Compact in lifts of 8 in. (200 mm) or less.

Step 5: Install Additional Courses

- Remove all excess material from the top surface of AB units. This can be done when installing the next course of block, by sliding the block into place.
- Stack the next course of blocks so that the vertical seams are offset from the blocks below by at least 3 in. (75 mm) or 1/4 the length of the block.
- Check and adjust for level, alignment and the wall batter as the wall stacks up.
- Fill the block cores and behind the block with wall rock a minimum of 12 in. (300 mm). Use approved soils to backfill behind the wall rock.
- **From course 2 and above use a plate compactor to compact directly on the blocks as well as the area behind the blocks. Compact in lifts of 8 in. (200 mm) or less.**
- Complete wall to required height. See page 55 for information on wall ending options.
- Use 8 - 12 in. (200 - 300 mm) of low permeable fill on the last lift to finish off wall.

* For walls under 4 ft. (1.2 m), an 18 in. (460 mm) wide by 10 in. (250 mm) deep trench with 4 in. (100 mm) of wall rock base material is acceptable.

Gravity Wall Typical Cross Section

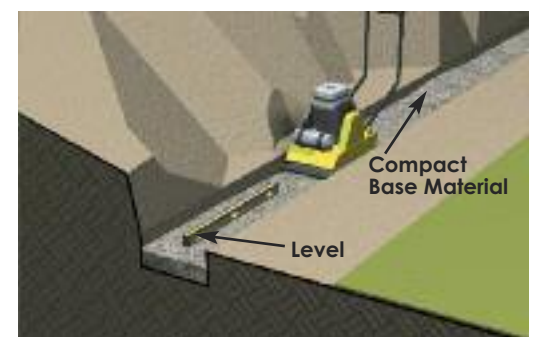
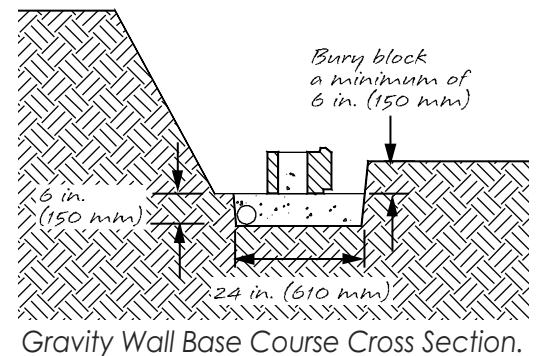
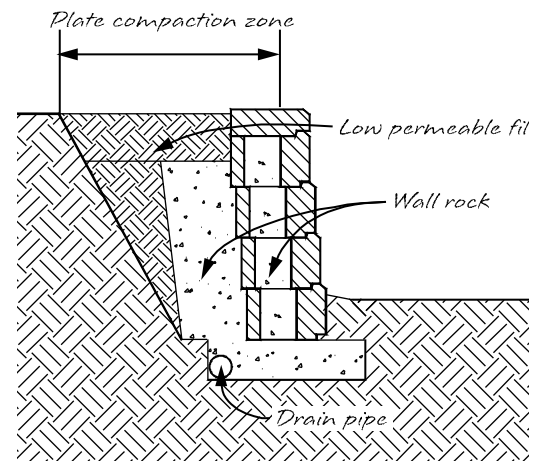

Install base material, level and compact.

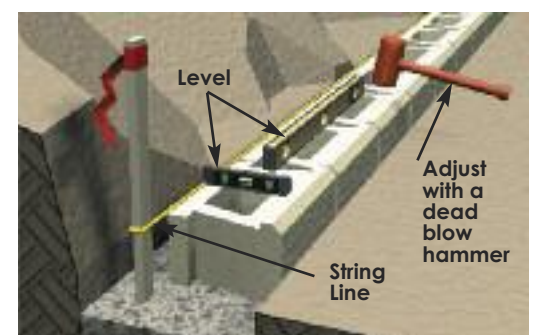

Level blocks, adjust where needed.

Reinforced Wall Construction



allanblock.com

Step 1: Site Prep and Excavation

Foundation soils at the bottom of the base trench must be firm and solid. If the soils are made up of heavy clay or wet soils, or the areas have been previously excavated, remove entire material and replace with granular base, compacting in 8 in. (200 mm) lifts or less.

- Remove all surface vegetation and organic soils. This material should not be used as backfill.
- Excavate behind the wall to accommodate the design length of the geogrid. Refer to the approved plans for exact length.
- Excavate base trench at the wall location. Dig the trench, per the approved plans, a minimum of 24 in. (610 mm) wide and 6 in. (150 mm) deep plus the required amount to accommodate the buried block.
- Buried block should be a minimum of 6 in. (150 mm) or 1 in. (25 mm) for each 1 ft. (300 mm) of wall height. See approved plans for exact amount needed.
- Compact and level base trench to 95% of Standard Proctor.

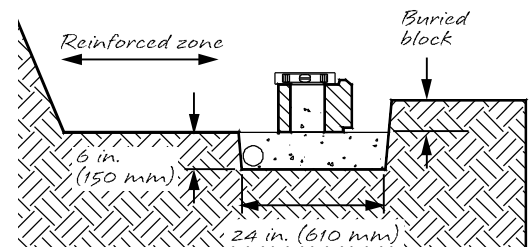

Reinforced Wall Base Course Cross Section.

Step 2: Install Base Material

The base material can be any compactible granular material. Allan Block recommends a well-graded aggregate, with a balanced mix of grain sizes, ranging from 0.25 in. to 1.5 in. (6 mm to 38 mm) diameter.

- Per the approved plans, place drain pipe at the back of the trench the length of the wall. The drain pipe will need to be vented to daylight or to a storm sewer system. See approved plans for location and specifications.
- Per the approved plan, place a minimum of 6 in. (150 mm) of base material in the base trench and rake smooth.
- Compact with a mechanical plate compactor.
- Check the entire length for level, and adjust as needed.

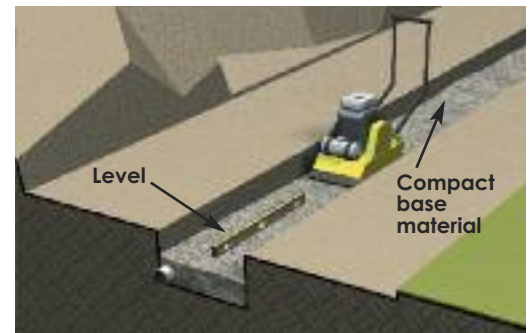

Install and compact base material.

Typical Reinforced Wall Cross Section

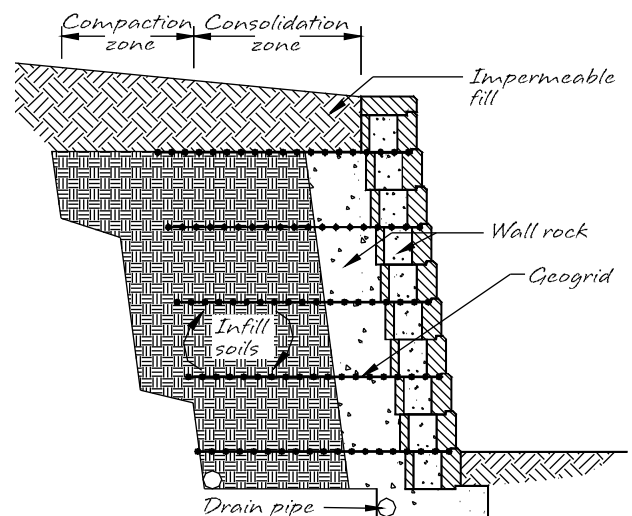

Reinforced Wall Structure

Reinforced Zone

The reinforced zone is located directly behind the block in two sections, the consolidation and the compaction zone. Both zones require compacting in maximum lifts of 8 in. (200 mm), to 95% Standard Proctor. Refer to the specifications in the approved plan for compaction requirements in these zones for each project.

Consolidation Zone

The consolidation zone runs from the back of the block back 3 ft. (0.9 m) into the infill soil. Only mechanical plate compaction equipment shall be allowed within the consolidation zone.

Compaction Zone

The compaction zone runs from the back of the consolidation zone to the cut in the slope. Heavier compaction equipment can be used in this zone provided no sudden braking or sharp turning occurs.

Reinforced Wall Construction

Step 3: Install Base Course

- **Begin at the lowest wall elevation.**
- Place all units top side up with the raised front lip facing up and in the center of the base material.
- Check and adjust for level and alignment of all AB units. Check block for level frequently from side-to-side and front-to-back. Verify the proper position of all AB units by examining a string line across the back of the blocks or by sighting down the back of the raised front lip.
- Make minor adjustments by tapping the AB units with a dead blow hammer or by placing up to 0.5 in. (13 mm) of coarse sand under the units.
- Irregularities in the base course become larger as the wall stacks up. Careful attention to a straight and level base course will ensure a quality finished wall.

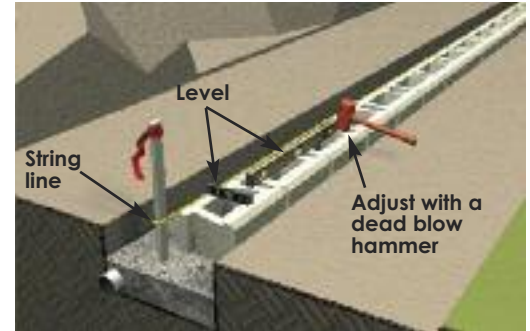

Install base course.

Step 4: Install Wall Rock and Backfill Material

- Fill the hollow cores of the base course and 12 in. (300 mm) behind the block with wall rock. A compactible aggregate ranging in size from 0.25 in. to 1.5 in. (6 mm to 38 mm) in diameter, and containing less than 10% fines is recommended.
- Use approved infill soils to backfill behind the wall rock and in front of the base course.

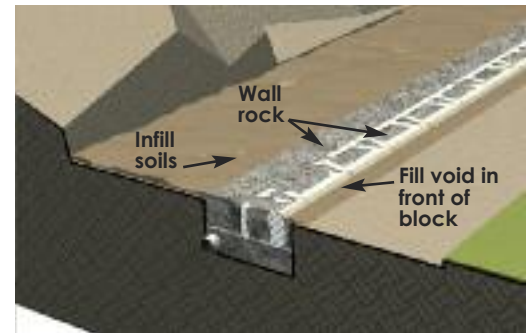

Install wall rock.

Step 5: Compact

Compaction of the material behind the block is critical for a quality wall.

- Use a mechanical plate compactor to consolidate the wall rock, then compact the backfill material immediately behind the block. Compact in a path parallel to the wall, working from the back of the block to the back of the backfill material. See page 33 for additional details on compaction.
- Check the base course for level and adjust as necessary.
- All backfill soils must be compacted to a minimum 95% Standard Proctor. Use equipment appropriate for the soil being compacted.
- Remove all excess material from the top surface of all AB units. This prepares a smooth surface for placement of the next course. This can be assisted when installing the next course of block, by sliding the block into place.
- **Every course after the first course requires compaction starting on the block.**

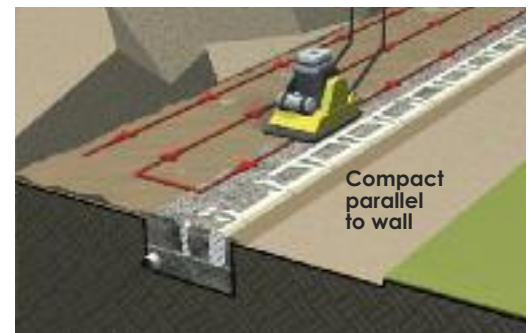

Compact wall rock and backfill soils.

Stepping Up The Wall Base

Walls built on a sloping grade require a stepped base.

- Begin excavation at the **lowest point** and dig a level trench into the slope until it is deep enough to accommodate the base material and one entire block.
- At this point step up the height of one block, and begin a new section of base trench.
- Continue to step up as needed to top of slope.
- **Always bury at least one full unit at each step.**

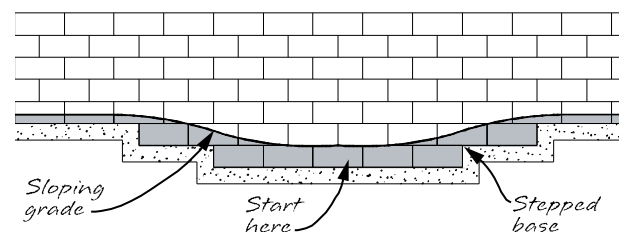

Reinforced Wall Construction



allanblock.com

Step 6: Install Geogrid

Refer to the plans for placement of grid; this example starts on the base course.

- Cut sections of geogrid to specified lengths. Check manufacturer's grid specifications for strength, and roll or machine direction. Refer to the approved plans for exact size and location.
- Install the layer of geogrid by placing the cut edge to the back of the raised front lip and roll the layer out to the back of the excavation area. The excavation area must be fully compacted and level.
- Stack the next course of block on top of the geogrid, so that the blocks are offset from the blocks below. Each new course should be positioned so that the vertical seams are offset by at least 3 in. (75 mm) and are tight against the front edge of the units below. Perfect running bond is not required.
- Sight down the wall line to check for a straight wall. Blocks may be adjusted slightly to form straight lines or smooth flowing curves.
- Pull on the back of the grid to remove any slack. Stake in place before installing wall rock and approved infill soils.

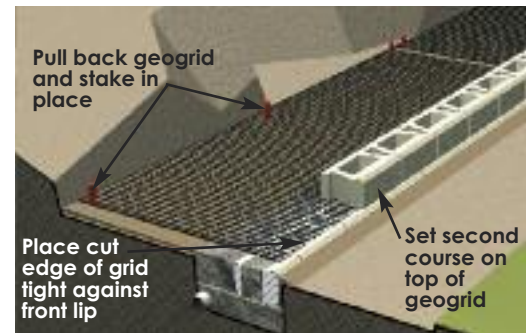

Install geogrid, stake in place.

Working With Geogrid

Geogrid typically comes in large rolls up to 13 ft (4 m) wide and 250 ft (76 m) in length. These "grids" also come in a variety of weights and strengths. Taller walls often require heavier strength grids, especially in the bottom portions of the wall.

It is critical that the correct grid is installed in the wall. Check the engineered plans and specifications.

Most grids are strongest along the roll or machine direction. Reinforced grid designs require that all grids are placed with the machine direction running from the face of the wall towards the back of the excavation area.

See page 58-60 for information on using grid with corners and curves.

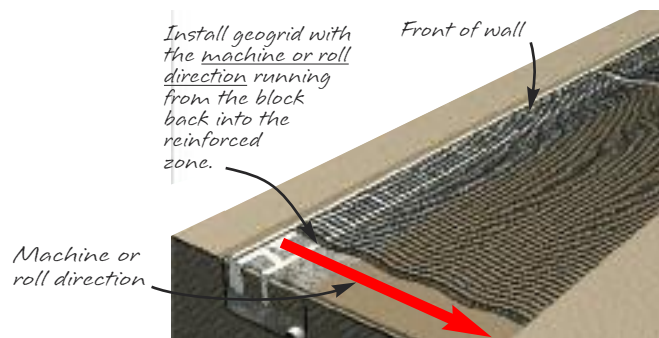
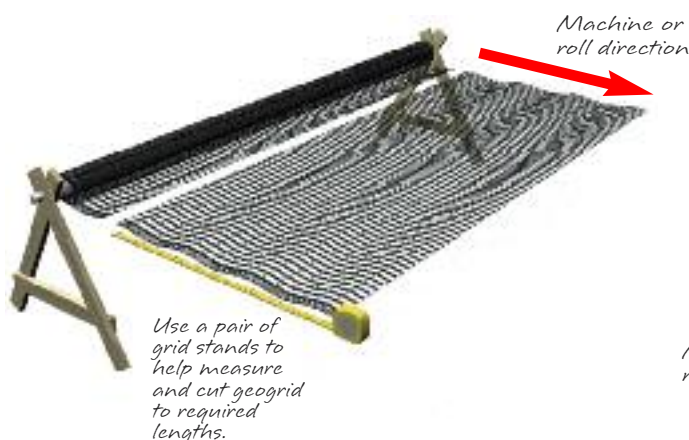

Reinforced Wall Construction

Step 7: Backfill and Compact

- Install wall rock in block cores and 12 in. (300 mm) behind wall. Use approved infill soils to backfill behind the wall rock in the reinforced zone.
- All wall rock and infill soils within 3 ft. (0.9 m) of the wall must be properly compacted using a mechanical plate compactor. **Compact in maximum 8 inch lifts (200 mm)**, this time **starting on the block** and working in a path that runs parallel to the block towards the back of the reinforced zone. Compact all materials to a minimum 95% Standard Proctor.
- Never operate compaction equipment directly on geogrid.
- **All heavy equipment must be kept at least 3 feet (0.9 m) from the back of the wall.** Wall designs typically do not account for surcharges from heavy compaction equipment. Even a properly installed and compacted wall will rotate forward when extreme surcharges from heavy equipment are applied to the top of the wall during construction and final grading.
- Check and adjust for level, alignment and the wall batter as the wall stacks up. It is acceptable to shim under blocks to compensate for a build up of tolerances or an out of level base condition. Asphalt shingles or geogrid work well when shims are required. The maximum allowable shim thickness per course is 1/8 in. (3 mm).
- Remove all excess wall rock and ridges or slag material from the top surface of all AB units. This prepares a smooth surface for placement of the next course. Plate compactors operated on top of the block will remove most slag material and prep the block for the next course. When installing the next course of block, sliding the block into place will also remove any slag material.

Step 8: Install Additional Courses

- Repeat steps 6 & 7 to complete wall to height required, installing grid where needed per the approved plans.
- Use 8 in. (200 mm) of impermeable fill on the last lift to finish off wall.
- See page 55 for information on ending and topping off the wall.

For information on Allowable Construction Tolerances see the AB Spec Book.

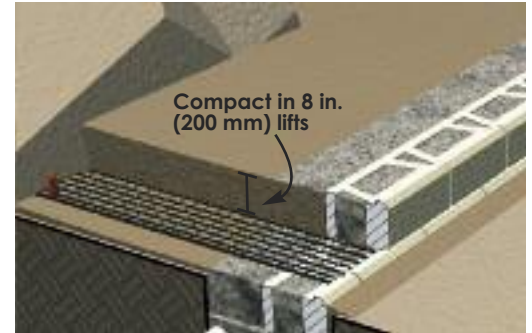

Compact in 8 in. (200 mm) lifts.

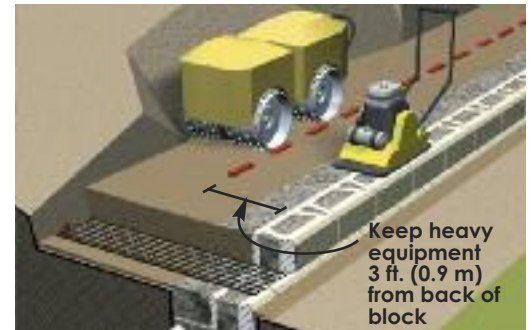

Keep heavy equipment away from the back of the block.

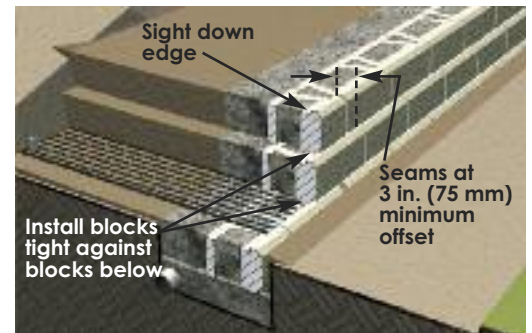

Install additional courses.

No-Fines Concrete Backfill



allanblock.com

No-Fines Concrete

Use of AB No-Fines Concrete Backfill has increased our ability to install reinforced walls in locations where typical construction would not be possible because of property line constraints or limited excavation options. When using the Allan Block products with No-Fines concrete, the permeable concrete actually attaches to the back of the block and extends the depth of the wall mass. This allows for taller walls with less excavation than conventional geogrid reinforced walls.

Typical geogrid reinforced walls require an excavation depth of 60% or more of the wall height; while a No-Fines reinforced wall, with similar site conditions, requires only 30 to 40% of the wall height. The recommended minimum structure depth of the No-Fines Concrete Backfill, measured from the face of the wall to the back of the mass, is 24 in. (60 cm). Limiting the excavation depth will not only save time and money, but it might make the difference between getting the job or not.

There are additional advantages to using the No-Fines solution. Contractors are able to build with better production rates and with less manpower. The use of No-Fines Concrete Backfill also eliminates the need for compaction and compaction testing of the reinforced soil. It provides superior wall drainage since the entire mass is permeable; therefore eliminating the need for wall rock in the cores and behind the wall. This pervious concrete backfill will provide a "solid" solution that can reduce the overall settlement behind the wall.

Engineering Properties:

- No-Fines Concrete Backfill can be used with any of the Allan Block Retaining Wall Collections.
- No-Fines Concrete Backfill typically consists of cement, fly ash, water and coarse aggregate. The quantity of cementitious material is approximately 500 lb/yd³ (297 kg/m³) with a water/cement ratio of approximately 0.30 – 0.40.
- No-Fines Concrete Backfill is designed using 3/8 in. to 3/4 in. (9.5 mm to 19 mm) aggregate with an aggregate/cement ratio of 6:1.
- The density of this product will vary with the density of the aggregate used, but will typically range between 100 lb/ft³ – 135 lb/ft³ (1600 kg/m³ – 2160 kg/m³).
- No-Fines Concrete Backfill has little to no slump and exerts pressure on the soil and Allan Block wall similar to loosely poured aggregate until cured.
- When using No-Fines Concrete Backfill, the backfill zone will also serve as the required drainage or wall rock zone within the cores and directly behind the wall.



No-Fines Concrete (NFC Backfill)

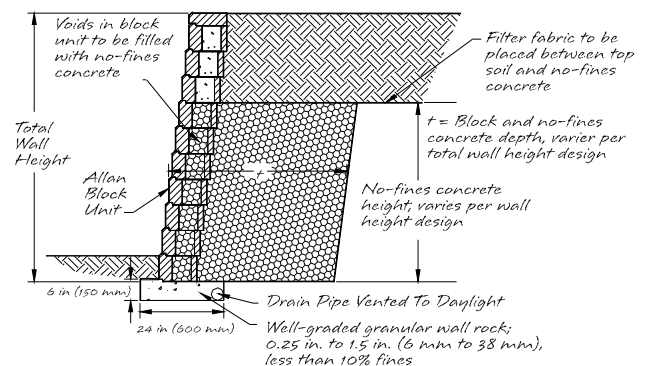

No-Fines Concrete Backfill

No-Fines Concrete Installation Steps

Refer to the page 26 for the complete installation steps when preparing the base trench and installing the first course of blocks. Once the first course of blocks are installed and leveled, following these simple steps to place the No-Fines Concrete Backfill:

- Fill all the voids in the block and backfill to the specified depth with the No-Fines concrete. Obviously, there are numerous ways to get the concrete mix to the back of the wall. Each site will be different.
- It is recommended, but not required; for straight wall sections, one of the back wings of the Allan Block units be removed to help secure the block face to the concrete backfill.
- The vertical height of a pour should not exceed 16 in. (406 mm) or two courses of block.
- Additional pours can be made as soon as the No-Fines concrete backfill in the previous lift has set, which is usually not longer than 2 to 3 hours. Additional courses of block could be stacked while waiting for the backfill to cure.



Additional Courses

- Brush the top of the blocks to remove any excess material. It is recommended that this be done before allowing the concrete to harden. Install the next course of blocks ensuring that they are level. Place the No-Fines Concrete Backfill the same way as outlined in the previous step.
- Continue these steps until the wall reaches its designed height.

Finishing Options

- Use 8-12 in. (200-300 mm) of low permeable fill on the last lift to finish off wall. Place a layer of landscape fabric horizontally above the No-Fines prior to placing the impermeable fill.
- Place a horizontal layer of filter fabric above the no-fines mass prior to placing low permeable fill above.
- See page 55 for information on ending and topping off the wall.

Excerpt from Table 6.2 shown on page 71.

No-Fines Chart					Soil Types: Coarse to medium sands, clean sand and gravel, little or no-fines - $\phi = 36^\circ$				Soil Types: Uniform to well graded sands, silty sands - $\phi = 32^\circ$				Soil Types: Sand-Silt-Clay mix, Clayey sands - $\phi = 27^\circ$			
					Depth of No-Fines including wall facing											
Condition Above Wall	Wall Height		Buried Block		12° (Ref) AB Stones only of the AB Collection		6° or 3° (Ref) AB, AB Europa and AB Fieldstone Collections (Excl. AB Stones)		12° (Ref) AB Stones only of the AB Collection		6° or 3° (Ref) AB, AB Europa and AB Fieldstone Collections (Excl. AB Stones)		12° (Ref) AB Stones only of the AB Collection		6° or 3° (Ref) AB, AB Europa and AB Fieldstone Collections (Excl. AB Stones)	
	ft	m	in	cm	ft	m	ft	m	ft	m	ft	m	ft	m	ft	m
Level Slope Above the Wall	4	1.2	4	10	-	-	-	-	-	-	-	-	2	0.7	2	0.7
	6	1.8	6	15	2	0.7	2.5	0.8	2	0.7	2.5	0.8	2.5	0.8	2.5	0.8
	8	2.4	8	20	2.5	0.8	3	1	2.5	0.8	3.5	1.1	3.5	1.1	3.5	1.1
	10	3.0	10	25	3.5	1.1	4	1.3	3.5	1.1	4	1.3	4	1.3	4.5	1.4

Working with Soils



allanblock.com

The soils used below and behind the wall are a critical part of the total wall structure.

A reinforced retaining wall is a structure containing three basic building materials - the block facing, the synthetic geogrid reinforcing materials, and the infill materials surrounding the geogrid layers.

Soils

Understanding the properties and characteristics of soils is key to building better walls. Different soil types will dictate the amount of time needed for compaction, the amount of reinforcement required, and potentially the cost of the wall.

Check the on-site soils carefully before beginning, and get a written identification of the soil type. A soils report from a local engineer will be required before a design and/or permit is issued for most walls above 4 ft. (1.2 m). Table 3.1 provides general classification of soils.

Soil Selection

If the on-site soils are of a very low quality, you should remove and replace them with better backfill material in the reinforced zone and the foundation area. The cost of removal will be offset by reduced reinforcement, faster compaction, and better long-term performance.

In the reinforced zone, the type of soil used will determine the amount of grid reinforcement needed. Heavy clays and organic soils are both unsuitable in the reinforced zone. Generally, any soil with a friction angle lower than 27° (Ref) or a plasticity index (PI) of greater than 20 should be removed and replaced. Soils with friction angles between 27° (Ref) and 31° (Ref) will require additional care, and attention to water management when placed and compacted. This will include extra inspections by an on-site engineer.

You must use infill soils that meet or exceed those specified in the engineered specifications and drawings. Have the soils tested before placing and compacting.

Table 3.1

Typical Friction Angle and Soil Unit Weights Compacted to 95% Standard Proctor		
Soil Type	Soil Friction Angle	Soil Unit Weight (pcf)
Crushed stone, gravel	34° +	110 - 135
Clean sands	32 - 34°	100 - 130
Silty sands/sandy silt	28 - 30°	110 - 125
Sandy clay	26 - 28°	100 - 120
Other soils	Determined by testing	

All soil friction angles and unit weights are provided as reference only and are subject to change based on geographic area and site conditions.



Compaction

Proper placement and compaction of the infill soils are critical. Compaction is often measured as a percentage of optimum consolidation of material being utilized. Foundation and infill soils require compaction to 95% of Standard Proctor, or 95% of the soil's maximum density. Local geotechnical and civil engineers are trained to test and measure compaction densities. On-site testing should be part of the wall project and included in the bid documents. Obtaining the optimum moisture content will ensure that the maximum density can be achieved. Soil that is too dry or too wet will not reach 95% of Standard Proctor.

The most important step in getting proper compaction is the placement of the soil in "lifts". Compacting in lifts, or layers, of less than 8 in. (200 mm) will facilitate quality compaction. Compaction equipment must be sized according to the type of material being compacted. Placement and compaction in lifts that exceed 8 in. (200 mm) will result in less than adequate soil strength. Consult with a local equipment supplier to ensure that proper compaction equipment is used. **Always backfill and compact after each course of block is placed.**

The consolidation zone runs from the back of the block back 3 ft. (0.9 m) into the infill soil. Only walk behind mechanical plate compaction equipment shall be allowed within the consolidation zone. A minimum of two passes with a walk behind plate compactor are required. Continue compaction process until proper compaction is achieved, starting on top of the block and compacting in paths that run parallel with the wall to the back of the consolidation zone.

Some applications require higher levels of compaction in the consolidation zone. Examples of these include additional walls or structures located within 3 ft (0.9 m) of the back of the wall.

Higher levels of compaction can be achieved within the consolidation zone by decreasing the lifts to 4 in. (100 mm) and compacting with walk behind compaction equipment, starting at the wall facing and running in paths that run parallel to the wall. Compacting in smaller lifts will achieve higher compaction levels and will not place lateral loads on the wall facing. Multiple passes of the compaction equipment will be required. Higher compaction levels reduce settlement over time.

Correct Compaction Process

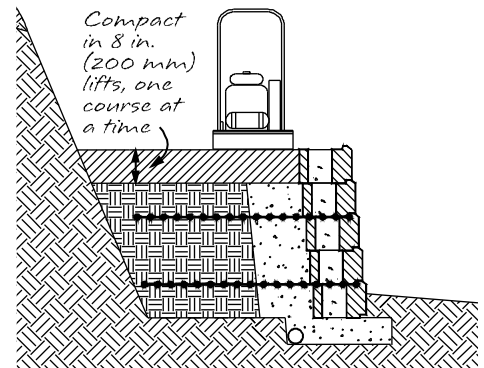

Keep all heavy equipment at least 3 ft. (0.9 m) away from back of blocks.

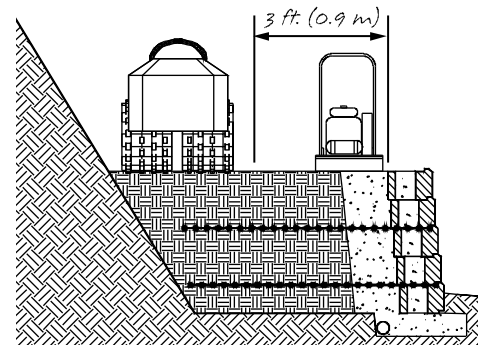

Water Management



allanblock.com

The design and performance of most retaining walls are based on keeping the reinforced zone relatively dry. To ensure that wall structures perform, the construction of the wall and layout of the site must be based on maintaining a soil moisture content that is relatively low. Relatively low equates to the moisture content required to achieve desired compaction.

Site civil engineering firms utilize a thorough understanding of the site to determine where water will come from and how it will be properly managed. Throughout their design process, sources of water are taken into account to handle above and below grade concentrations of water.

Contractors must understand the intent of the approved site plans and what will be required to protect the area impacted by the wall construction. Temporary berms may be required to direct water away from construction sites.

Allan Block walls may be designed with an array of details to ensure that the wall and reinforced soil structure remain free of excess moisture. Basic design details mandate toe drains for all walls over 4 ft. (1.2 m) in height, with slopes, or other structures above the wall. Once geogrid is introduced into the design, heel drains are also incorporated. In all cases wall rock is located within the cores of the block and a minimum of 12 in. (300 mm) behind the block. These three details are designed to remove incidental water within their respective locations and are not meant as primary drainage paths for above or below grade water management. Refer to your approved plans or the AB Spec Book for specific information on these items.



Typical Drain

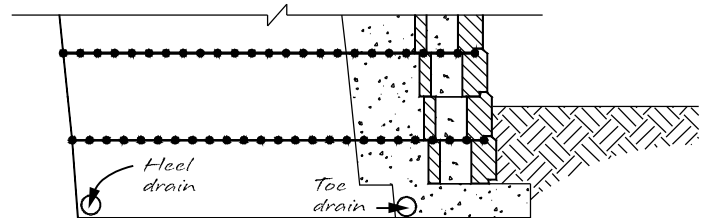

Drains must be vented to daylight or connected to a storm sewer system.

All drain pipes must be protected from migration of fine material. Refer to approved plans for construction details.



See page 65 for a cross section drawing of this drain.

Grading

During wall layout it is important to evaluate the entire site to determine if water will drain into the area where the walls will be constructed. Using simple berms and swales to divert the water around the wall can be easily done. Since walls are often built before the site is completely graded to its final configuration, temporary grading must be in place to ensure water will not be draining towards the construction area. Contact the local engineer of record and the site civil engineer for directions prior to proceeding with construction of the wall.

Ground Water

Ground water can be defined as water that occurs within the soil. Sources include surface infiltration, water table fluctuation and layers of permeable soils. Ground water movement must be prevented from coming in contact with the retaining wall structure, including the reinforced soil mass.

Construction details to prevent subsurface water from coming in contact with the retaining wall structure should be defined on the approved plans. Use blanket and chimney drains to intercept ground water from potentially infiltrating the reinforced mass. When ground water is encountered during construction work with the engineer of record to ensure that the water has been accounted for in the design.

Extra care must be employed to prevent water from entering the reinforced zone when non-permeable infill soils are used in wall construction.

Drain pipes used in toe or heel drain applications must be properly vented a minimum of every 50 ft (15 m). Methods to accomplish this include having drain pipes draining into the storm sewer system or vented to a lower elevation on the site. See approved plans for locations.

When venting to a lower elevation, it is important that all drain locations are properly marked during the construction phase and protected during and after the completion of the project to ensure that the drain pipe is not damaged or plugged. Rodent screens and concrete collars are examples of details employed to allow for water to flow through the outlet pipes and keep the pathway clear of debris. If details are not identified on the plans, request guidance from the local engineer or the site civil engineer.

Concentrated Water Sources

Prior to constructing the wall, review drainage plans and details with the general contractor or site civil engineer to identify all potential sources of concentrated water.

Examples that must be accounted for are:

- Below grade storm sewer pipes
- Water lines, mains or fire hydrants
- Grading of site
- Parking lots
- Catch basin to storm sewer system
- Roof down spouts
- Slopes above walls

Chimney Drain

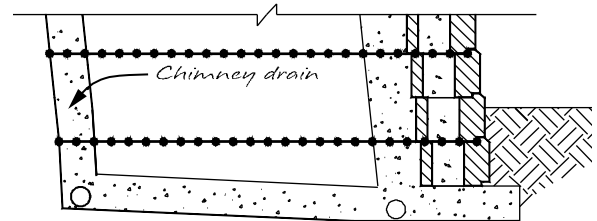

Blanket Drain

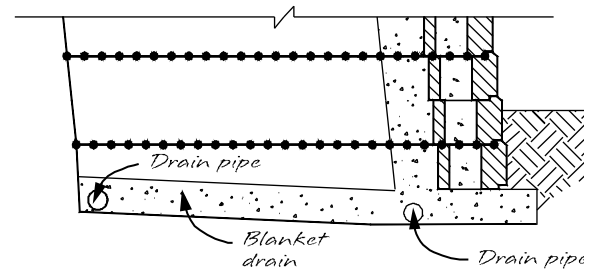

Vent Drain Pipe Option

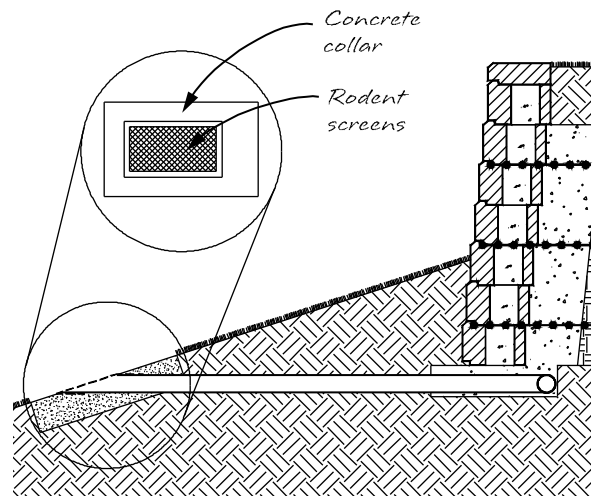

BUILD PATTERNED WALLS



allanblock.com

Installation details for building patterned for Allan Block's
AB and AB Europa Collection retaining walls.

Wall Patterns	37
Patterned Wall Construction	38
Patterned Wall Construction Tips	40

Wall Patterns

All of the Allan Block Collections can be used to create a variety of pre-set and random patterns. A pre-set pattern is repeated every two or three courses of block. A single course consists of a full size block, approx 8 in. (200 mm) tall. Random patterns used on a reinforced wall require a level surface every 2 or 3 courses for proper installation of geogrid. See the approved plans for which layers the geogrid reinforcement will be required.



Note:

- Patterned walls will have a 6° setback.
- Walls with curves should always use the 2 course pattern to minimize cutting and fitting.
- The base course needs to be a full course of full size blocks. For each 10 ft. (3 m) length you will need 7 blocks.

Standard Patterns - Uses all blocks in the collections

Two Course Pattern

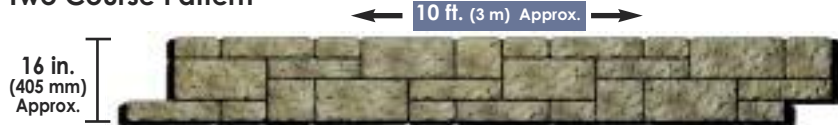

AB Collection Blocks Required	AB Europa Collection Blocks Required
6 AB Classic or AB Stones	6 AB Dover
4 AB Jumbo Junior	4 AB Palermo
8 AB Lite Stone	8 AB Barcelona
8 AB Junior Lite*	8 AB Bordeaux

Three Course Pattern

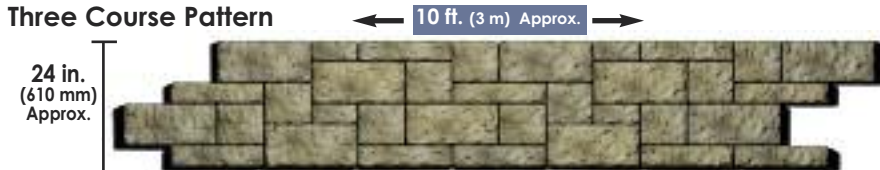

AB Collection Blocks Required	AB Europa Collection Blocks Required
10 AB Classic or AB Stones	10 AB Dover
10 AB Jumbo Junior	10 AB Palermo
10 AB Lite Stone	10 AB Barcelona
4 AB Junior Lite*	4 AB Bordeaux

* Note: In the AB Collection, if the AB Junior Lite is not available an AB Lite Stone will need to cut in half. See page 41 for more information.

Lite Patterns - Uses only the smaller blocks in the collections

Two Course Pattern



AB Collection Blocks Required	AB Europa Collection Blocks Required
7 AB Jumbo Junior	7 AB Palermo
15 AB Lite Stone	15 AB Barcelona
12 AB Junior Lite*	12 AB Bordeaux

Three Course Pattern

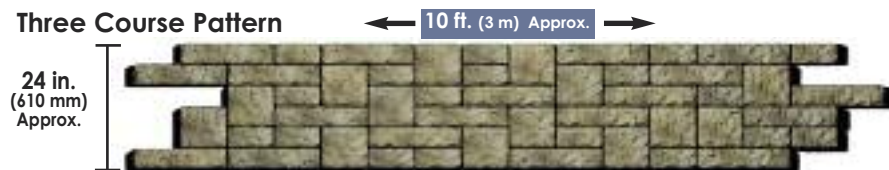

AB Collection Blocks Required	AB Europa Collection Blocks Required
14 AB Jumbo Junior	14 AB Palermo
19 AB Lite Stone	19 AB Barcelona
18 AB Junior Lite*	18 AB Bordeaux

Note: Maximum recommended wall height for Lite Patterns is 6 ft. (1.8 m).

For more information see the Allan Block Patterns document available at allanblock.com

Patterned Wall Construction



allanblock.com

Step 1: Excavate and Install Base Course

Refer to page 26 for a detailed description on how to install the base course.

Basic steps include: 1) Site prep and excavation, 2) Install base material, 3) Install base course 4) Install wall rock and backfill materials, geogrid if necessary, and 5) Compact.

Note: Full-sized blocks should always be used for the base course. This will speed the leveling and installation of the first course.

Step 2: Install Geogrid

Refer to the plans for placement of grid; this example requires grid on top of the base course.

- Remove all excess material and slag from the top surface of the base course. This prepares a smooth surface for placement of the geogrid and the next course of blocks.
- Cut sections of geogrid to specified lengths. Check manufacturer's grid specifications for strength and roll or machine direction. Refer to the approved plans for exact size and location.
- Install the layer of geogrid by placing the cut edge up to the back of the raised front lip and roll the layer out to the back of the excavation area to the length specified in the approved plans.

Step 3: Install the Multiple-Course Pattern

The example shown here uses a 2 course pattern. Check the approved plans to determine the best pattern option for the project. See page 37 for more information on patterns.

- Stack the first course of the pattern on top of the geogrid and the base course.
- Check blocks for level, and make adjustments as needed. Pull on the back of the geogrid to remove any slack. Stake geogrid in place.
- Install wall rock in the block cores and 12 in. (300 mm) behind the blocks. Compact using a shovel handle inside the cores. Check blocks for level. See below for more information on compaction in the block cores.



Install base course and compact.

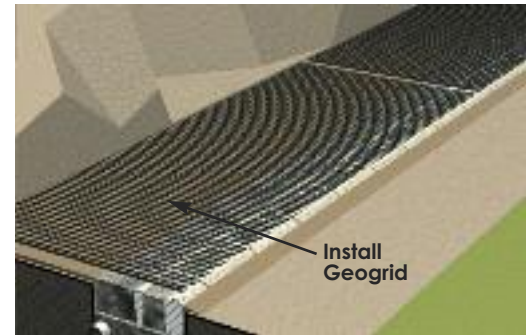

Install geogrid.

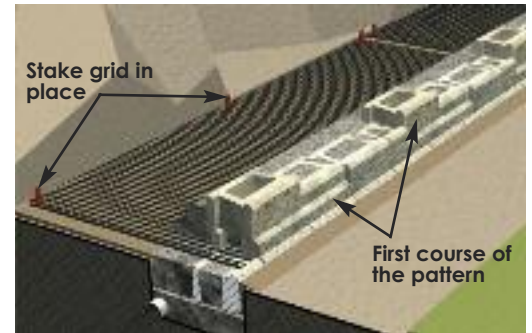

Stack first course of pattern and backfill wall rock in block cores.

Compaction on Patterned Walls

Compaction in the block cores needs to be done regularly when working with patterned walls. This can be done by using the end of a shovel to compact the wall rock, adding additional rock if necessary.



At each 8 in. (200 mm) lift, compact the block cores with the end of a shovel, and the area directly behind the block with a plate compactor per the procedures described in this manual.

At the conclusion of each pattern, the top of the wall will be level. Run the plate compactor over the top of the blocks to consolidate the wall rock. Place grid if required, and begin the next pattern.

Typical Reinforced Patterned Wall

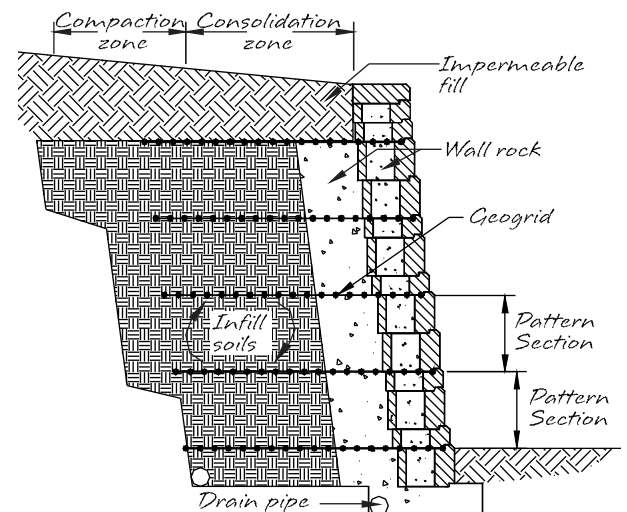

Patterned Wall Construction

- Use approved infill soils to backfill behind the wall rock in the reinforced zone. **The height of the wall rock and backfill material cannot exceed 8 in. (200 mm) before compacting.** The top of the blocks will not always match up with each lift of soil.
- Using a mechanical plate compactor, compact the wall rock and infill materials behind the wall in **maximum 8 in. (200 mm) lifts.** Compact immediately behind the wall in a path parallel to the wall, working from the back of the wall to the back of the excavated area. Compact to a minimum of 95% Standard Proctor.
- Check blocks for level, and then install the remainder of the 2 course pattern. Install wall rock in the block cores and behind the blocks as before. Use approved infill soils to backfill behind wall rock. Check blocks for level and for batter.
- With the first multiple-course pattern completed, use a plate compactor to compact the wall rock in the block cores and the wall rock behind the blocks. The first pass of the plate compactor should be directly over the top of the block cores.
- After running the plate compactor on top of the blocks and wall rock, compact the infill material immediately behind the wall. Compact in a path parallel to the wall, working from the front of the wall to the back of the infill material. Compact to a minimum of 95% Standard Proctor.
- Check and adjust for level and alignment and wall batter as the wall stacks up. It is acceptable to shim under blocks to compensate for a build up of tolerances or an out of level base condition. Asphalt shingles or geogrid work well when shims are required. The maximum allowable shim thickness per course is 1/8 in. (3 mm).

Step 4: Install The Second Multiple-Course Pattern

Refer to the approved plans to determine if geogrid reinforcement will be required on the next course of the pattern being used.

- Repeat Step 2 to install geogrid between the patterns when required per the approved plans.
- Repeat Step 3 for each pattern being installed. Each additional pattern will need to be offset from the pattern below to avoid a repetitive look.

Note: Keep all heavy equipment at least 3 feet (0.9 m) away from the back of the wall.

Step 5: Ending and Topping off Wall

Completing a patterned wall is the same as for a standard wall. See page 55 for finishing details. The only requirement is that a multiple course pattern must be completed so that the top course of the blocks form a level surface.

- Use 8 in. (200 mm) of impermeable fill on the last lift to finish off wall.

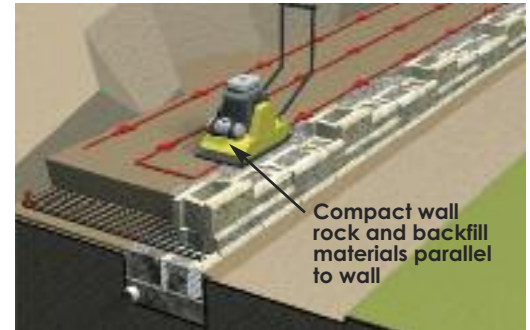

Compact behind the wall.

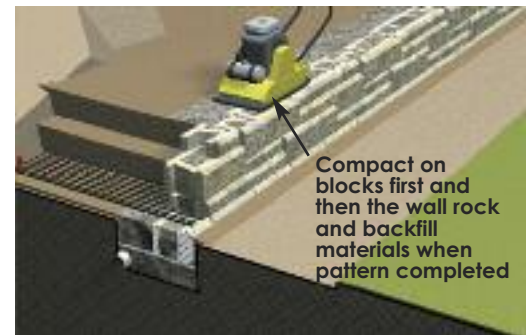

Complete pattern and compact.

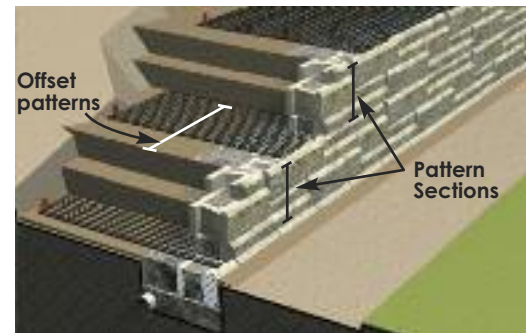

Install geogrid and additional patterns.

Patterned Wall Construction Tips



allanblock.com

Reinforced Wall Construction

- For walls that require geogrid reinforcement, selection of which pattern to use is determined by the grid spacing shown on the approved plans. If grid is required every 2 courses, then use a 2 course pattern; if 3 course grid spacing is required, use a 3 course pattern.
- If building with a random pattern, the pattern must be leveled off at the appropriate courses to allow for the installation of geogrid on a flat surface.

Ending Patterned Walls - Step Downs

Patterned walls may be ended with step ups or turn-ins. When ending a patterned wall, discontinue the pattern and randomly adjust as necessary to meet the site conditions. See page 55 for more information on ending walls.

Curves

When building curves, the 2 course pattern is easier to work with than the 3 course pattern. The 3 course pattern will require more custom fitting or cutting of blocks to ensure a tight fit.

Inside curved walls are easily constructed by maintaining a tight spacing at the front of the wall face. For tighter radii, it may be necessary to cut out parts of the bottom notch in order for the blocks to fit tightly together. See page 56.

Outside curved walls The wall will "tighten" as the height increases. There are three methods to adjust for the tightening effect:

- On the first course of the pattern, open the spacing between blocks slightly so that the top course(s) of the pattern will need minimal cutting.
- Reduce the lengths of the blocks by shortening them, using a saw with a diamond blade.
- Remove parts of the bottom notch for the blocks to fit tightly together. See page 56.

The best answer is to always use the 2 course pattern when building curves.

Ending Patterned Walls



Dash of Ashlar

The AB Collections have been created in modular sizes to allow for easy construction of patterned walls. Selected areas of non-patterned walls can also contain patterns. With the modular design, the blocks can be installed with ease.



Patterned Wall Construction Tips

Corners

Outside corners are easily built using AB Corner Blocks.

- Start at the corner and build the wall working out in both directions.
- When ending a patterned wall with a corner, use a random selection of blocks to transition from the patterned courses into the AB Corner Blocks.

Note: Always start the base course at the lowest elevation, then beginning additional courses at the corner will minimize cutting.

Inside corners are constructed in the same manner as for non-patterned walls.

- Remove the top lip of the course where the walls intersect. See page 59.

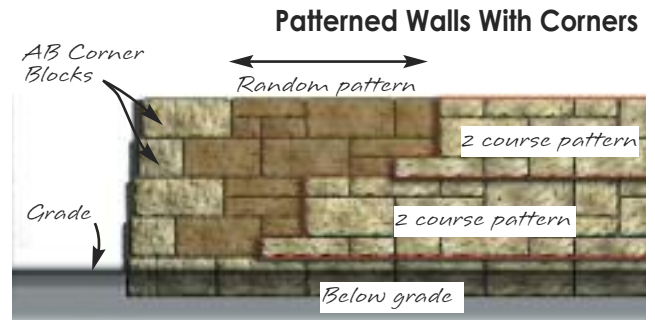

Stairs

When building steps into patterned walls, use the full-sized AB Blocks for step blocks. See page 61 for stair construction details.

Step-Ups

When building a wall always start the base course at the lowest elevation. See page 27 for more information on construction.

Additional Construction Tips

- If an AB Junior Lite is needed and not available, an AB Lite Stones will need to be cut to produce 2 half lite blocks. Pre-cut the desired number of blocks to speed installation.
- Offset each new pattern from the pattern below to maintain the "random" appearance.
- With walls that have numerous inside and outside curves, use a 2 course pattern to ease the installation process.

Patterned Walls With Stairs



Cutting A Block In Half



BUILD AB FIELDSTONE[®]



allanblock.com

Installation details for building with the AB Fieldstone retaining wall system.

Gravity Wall Construction	45
Reinforced Wall Construction	47
AB Fieldstone Construction Tips	49





ab
ALLAN
BLOCK

AB Fieldstone®
Green Natural Friendly
allanblock.com

Facing Series: Sierra
Color: Rustic Creek

AB Fieldstone® Collection

The First Eco-Friendly Concrete Retaining Wall System

AB Fieldstone is an innovative new concept in the manufacture and use of segmental retaining wall (SRW) systems. By manufacturing this system in 2 pieces - the facing unit and the anchoring unit, Allan Block has opened the door to many benefits that are not only **Green**, but **Natural** and **Friendly** as well.

The *facing units* are created with differing textures and colors to emulate natural stone, which are referred to as *Series*. There are currently four Series to choose from: Sierra, Cascade, Colonial and Heritage Series, with additional ones in development. This product concept provides the potential for a variety of new styles and textures. Visit allanblock.com for all the latest information.

The *anchoring units* are produced with local recycled materials while maintaining a beautiful and distinctive look. Manufactured in universal sizes to work with any of the different facing Series, this innovative new product has unlimited possibilities.



The *Dogbone units* are used to create parapets in many widths. The parapets can be used to finish off the top of a retaining wall with seating or planters or can be built as free standing walls.

See pages 52-53.

AB Dogbone unit - NEW



allanblock.com



Anchoring unit - available in two universal sizes and produced with local recycled materials.

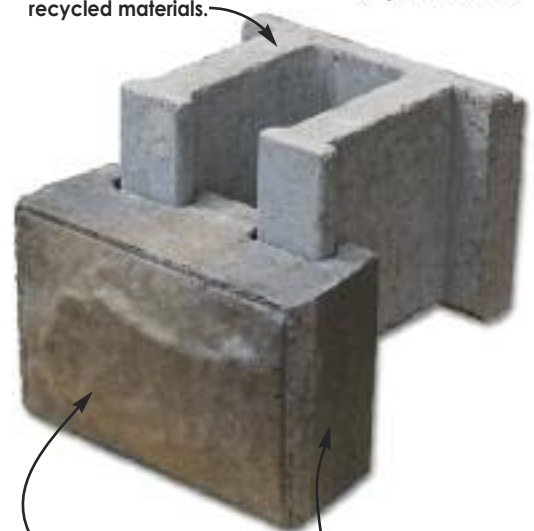

Facing unit - available in different sizes and Series styles. Each Series has varied block faces to ensure a random look, just like you would see in nature.

Some of the facing units are manufactured with a textured side eliminating the need for extra blocks when building corners or ending walls.

AB Fieldstone retaining walls can help projects achieve **LEED® points** in 14 different credits.



allanblock.com

AB Fieldstone comes as close as you can get to matching the raw beauty of natural stone. With the many faces of AB Fieldstone that resembles hand-hewn limestone, chisled sandstone, and rough cut stone to name a few the choices are sure to provide a timeless elegance to any surrounding. By blending the Series faces together in a project it creates a way for many more unique looks and styles.

To compliment the different Facing Series available, you have a range of colors to choose from. For cool tones choose our *Glacier Bay*, *Sandstone*, *Kasota Gold* or *Black Hills*, for warmer earth tones choose the *Rustic Creek* or *Walnut* or for an exciting rich red tone try our *Canyon Springs*.

With the Series choices and color options, this system truly has unlimited design potential.

The AB Fieldstone Collection has everything you need for a stylish look as well as being a recycled product. Not to mention, it also has many "Friendly" advantages. The *lighter-weight two-piece system* makes it easy to handle. With the ability to build *taller gravity walls* with the same installation practices as our AB and AB Europa Collection, there is no new installation process to learn. The exciting advantages of the facing unit with its *built-in corner* and *height control*, where every facing unit is the exact same height, makes building with AB Fieldstone a hassle free experience.

Allan Block is continually developing new Series looks and complimenting colors, so visit allanblock.com for the latest information. While you are there check out our easy to use estimating tools to determine all your material needs.



BUILD AB FIELDSTONE

AB Fieldstone Gravity Wall Construction

For complete details on the proper steps for site prep, drainage requirements and installing the base material, see page 25 - Steps 1 and 2. Most designs will require a local wall design engineer or a site civil engineer to develop approved plans. The projects must be built to these approved plans and specifications.

Step 1: Install Base Course

- **Begin at the lowest wall elevation** by placing the AB Fieldstone facing units on the base material towards the front of the trench, leaving room for the AB Fieldstone anchoring unit so when entire assembly is installed it is centered on the base materials. Check each unit and adjust for level and alignment. The facing units can be randomly flipped upside down to give different facing appearances.
- For proper placement of the AB Fieldstone anchoring units, use a brick hammer to create a small trench to allow for the lip.
- Install the AB Fieldstone anchoring units into the receiving slots of the facing units with the lip facing down in the trench just created. Make adjustments to ensure anchoring units are installed reasonably level with the facing unit. **The anchoring units should never be installed higher than the facing unit.** Except for special applications like corners, each anchoring unit should match up with one facing unit.
- Drain pipe is required for walls over 4 ft. (1.2 m) tall or are constructed in silty or clay soils. See approved plans for location and specifications. Refer to page 65 for details on an alternate drain location.

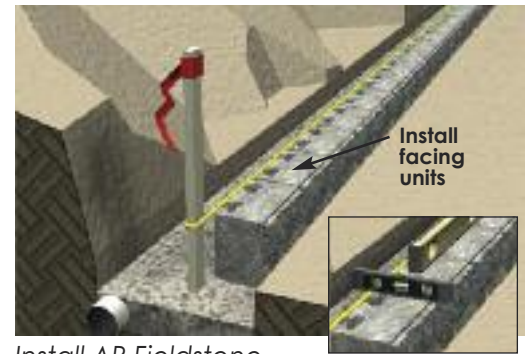

Install AB Fieldstone facing units. Level and adjust.

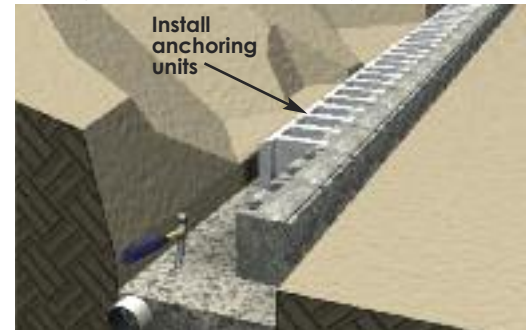

Install AB Fieldstone anchoring units.

Step 2: Install Wall Rock and Backfill Materials

- Fill the hollow cores and a minimum of 12 in. (300 mm) behind the wall with wall rock. Install the wall rock to be level or below the receiving notch of the anchoring unit.
- Use approved soils to backfill behind the wall rock and in front of the base course.
- Use a plate compactor to consolidate the area behind the blocks.
- **Compact in lifts of 8 in. (200 mm) or less.**

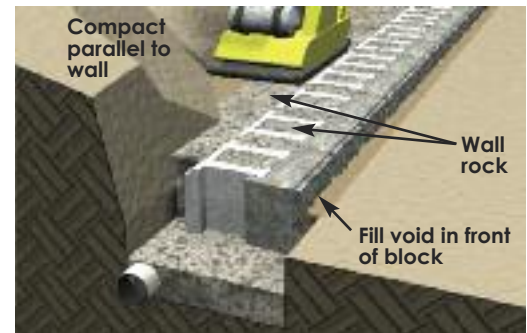
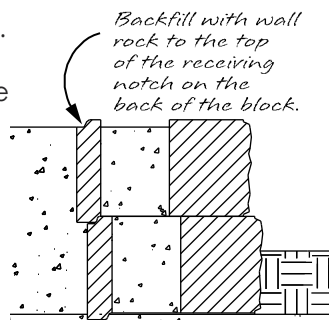

Install and compact wall rock and backfill soils.

AB Fieldstone Anchoring Units

AB Fieldstone is a multi-piece retaining wall system where each block assembly consists of a facing unit and an anchoring unit. These universal anchoring units, short anchoring unit (SAU) and long anchoring unit (LAU), are made of recycled materials and are used with the 812 and 824 facing units. The long anchoring unit is an option for job sites that require taller walls, but do not have room for excavation and geogrid placement.

- The maximum gravity wall heights using short anchoring units, with either of the two facing units, is up to 5 ft. 8 in. (1.7 m) in good soil conditions.
- The maximum gravity wall heights using long anchoring units, with either of the two facing units, is up to 9 ft. 8 in. (3.0 m) in good soil conditions.

Good soils conditions are defined as well-graded compactible granular aggregate, with an internal angle of friction of 36° or greater.

You should always consult a registered professional engineer to determine actual site specific requirements or to account for seismic loading.

See page 13 for the complete Maximum Gravity Wall Height Chart.



812 facing units with short anchoring unit (SAU)



824 facing unit with short anchoring unit (SAU)



Long anchoring unit (LAU)

Use with 812 or 824 facing units

AB Fieldstone Gravity Wall Construction



allanblock.com

Step 3: Install Additional Courses

- Remove all excess material from the top surface of the AB Fieldstone units. This should include running a brush or broom across the receiving notch to remove any debris.
- For faster installation and alignment of the second course, install the first AB Fieldstone facing unit and AB Fieldstone anchoring unit at the same time. Make adjustments so that the vertical seams are offset from the blocks below by at least 3 in. (75 mm) or ¼ the length of block.
- Install the rest of the AB Fieldstone facing units using the first block as a placement guide.
- Place AB Fieldstone anchoring units into the receiving slots of facing units. Slide the two-piece assembly so that the lip of the anchoring unit is placed into the receiving notch of the block on the course below. Each anchoring unit should match up with one facing unit.
- Check and adjust for level and alignment of the AB Fieldstone facing units.
- Fill the hollow cores and a minimum of 12 in. (300 mm) behind the wall with wall rock. Install the wall rock behind the anchoring unit to be level or below the receiving notch or approximately 0.5 in. (12 mm) below the top of the anchoring unit.
- Use approved soils to backfill behind the wall rock.
- **From course 2 and above use a plate compactor to compact directly on the blocks as well as the area behind the blocks. Compact in lifts of 8 in. (200 mm) or less.**
- Remove excess material from the top surface and repeat steps to complete the wall to the height required. See page 55 for information on ending walls with turn-ins.



Sweep to remove excess materials for proper placement of next course.

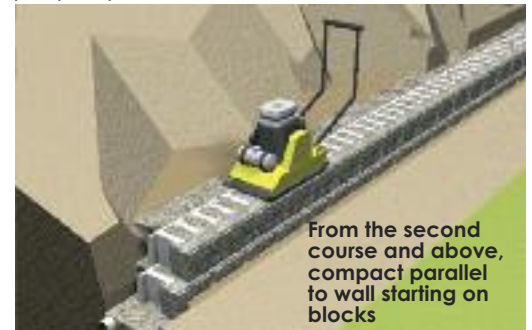

From the second course and above, compact parallel to wall starting on blocks. Compact wall rock and backfill soils starting on the blocks.

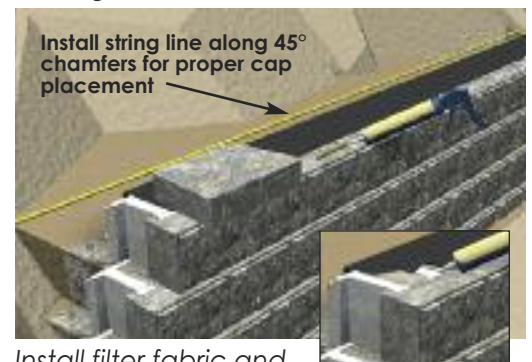

Install filter fabric and string line to place AB Caps.

Finishing an AB Fieldstone Wall

Filter Fabric Above Top Block/ Below Cap

Filter fabric is used on top of the top course of blocks and below the caps to cover the back of the anchoring units. This will allow plantable soil to be placed flush against the cap unit.

- Place a strip of filter fabric along the top of the anchoring units on the top course of wall. Position so that the fabric starts at the back of the facing unit and goes over the anchoring unit and down along the back of the anchoring unit.
- Be sure to leave the top surface of the facing unit exposed so that the cap sealant can be placed on the facing unit.
- Finish the wall with AB Capstones. Place first capstone on the wall to include a 1.5 - 2 in. (40 - 50 mm) overhang.
- Run a string line the length of wall to mark placement of additional capstones. To get a consistent point, use the 45 degree chamfers at the end of each cap as alignment points for string line.
- Use a flexible masonry adhesive, NP1 or equivalent, to secure the capstones in place. Put a small bead of sealant along the sides of the caps as well.
- Backfill behind the last course and behind the AB Capstone with impermeable fill to allow for planting up to the back of the wall.

Note: To help hold the filter fabric in place while backfilling, place a spot of sealant between the fabric and the anchoring unit.

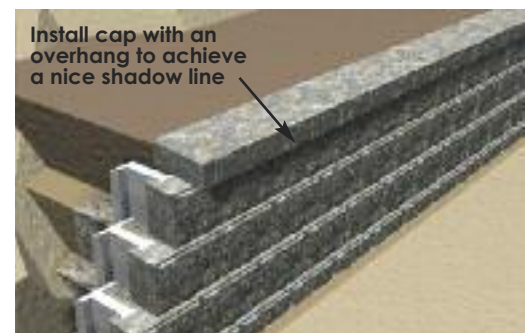
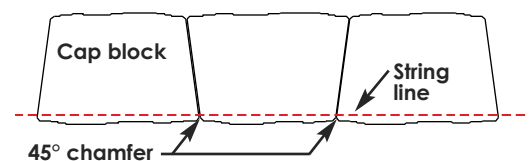

Install cap with an overhang to achieve a nice shadow line

AB Fieldstone - Reinforced Wall Construction

See page 26 for complete details on proper steps for site prep, drainage requirements and installing the base material for a reinforced wall. Projects must be built to the approved plans and specifications provided by a local engineer.

Step 1: Install Base Course

- **Begin at the lowest wall elevation** by placing the AB Fieldstone facing units on the base material towards the front of the trench, leaving room for the AB Fieldstone anchoring unit so when entire assembly is installed it is centered on the base materials. Install a string line at the back of the facing unit to ensure the proper positioning of all facing units.
- Adjust for level and alignment as each facing unit is installed.
- For proper placement of the AB Fieldstone anchoring units, use a brick hammer to create a small trench to allow for the lip.
- Install the AB Fieldstone anchoring units into the receiving slots of the facing units with the lip facing down in the trench just created. Make adjustments to ensure anchoring units are installed reasonably level with the facing unit. **The anchoring units should never be installed higher than the facing unit.** Except for special applications like corners, each anchoring unit should match up with one facing unit.
- Drain pipe is required for walls over 4 ft. (1.2 m) tall or are constructed in silty or clay soils. See approved plans for location and specifications. Refer to page 65 for details on an alternate drain location.

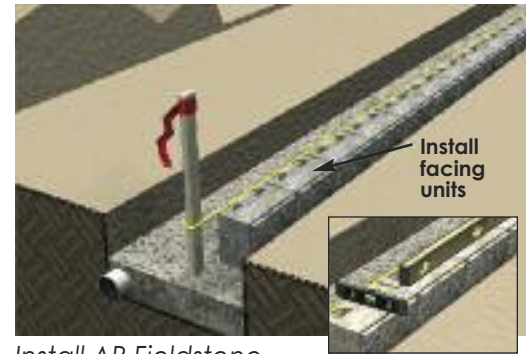

Install AB Fieldstone facing units. Level and adjust.

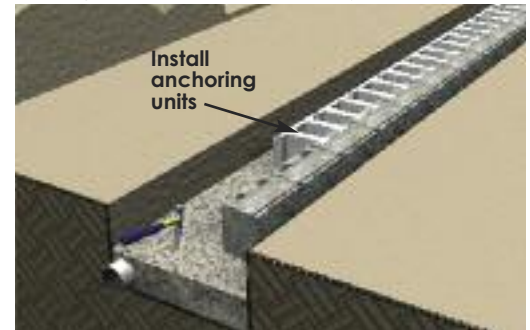

Install AB Fieldstone anchoring units.

Step 2: Install Wall Rock and Backfill Materials

- Fill the hollow cores of the base course and a minimum of 12 in. (300 mm) behind the wall with wall rock. Install the wall rock to be level or below the receiving notch of the anchoring unit, see page 45. A compactible aggregate ranging in size from 0.25 in. to 1.5 in. (6 mm to 38 mm) in diameter, and containing less than 10% fines is recommended.
- Use approved soils to backfill behind the wall rock and in front of the base course.

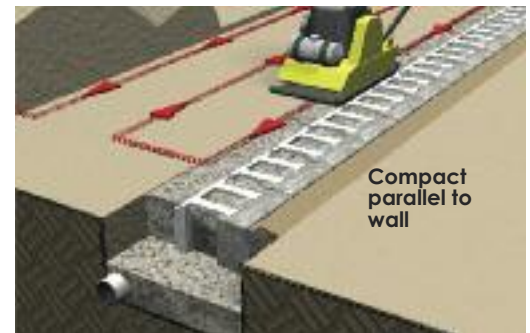

Install wall rock. Compact wall rock and backfill soils.

Step 3: Compact

Compaction of the material behind the block is critical for a quality wall.

- Use a mechanical plate compactor to consolidate the wall rock, then compact the backfill material immediately behind the block. Compact in a path parallel to the wall, working from the back of the block to the back of the backfill material. See page 33 for additional details on compaction.
- Check the base course for level and adjust as necessary.
- All backfill soils must be compacted to a minimum 95% Standard Proctor. Use equipment appropriate for the soil being compacted.
- Remove all excess material from the top surface of all AB units. This prepares a smooth surface for placement of the next course. This can be assisted when installing the next course of block, by sliding the block into place.
- **Every course after the first course requires compaction starting on the block.**

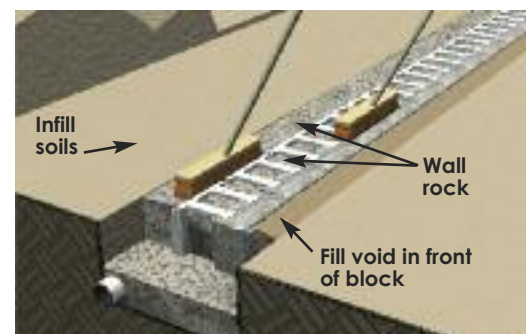

Sweep to remove excess materials for placement of geogrid.

AB Fieldstone - Reinforced Wall Construction



allanblock.com

Step 4: Install Geogrid

- Cut sections of geogrid to specified lengths. Check manufacturer's grid specifications for strength, and roll or machine direction. Refer to the approved plans for exact size and location.
- After the base course of blocks has been installed, roll out the geogrid reinforcement starting in the middle of the AB Fieldstone facing unit and extending back to the excavated area. The excavated area must be fully compacted and level.
- Stack the next course of block (facing and anchoring units) on top of the geogrid so the blocks are offset from the blocks below. Each new course should be positioned so the vertical seams are offset by at least 3 in. (75 mm) or 1/4 the length of the block. Perfect running bond is not required. The facing units can be randomly flipped upside down to give different facing appearances.
- Sight down the wall line to check for a straight wall. Blocks may be adjusted slightly to form straight lines or smooth flowing curves.
- Pull on the back of the geogrid to remove any slack. Stake in place before installing wall rock and approved infill soils.



Install geogrid. Start in the middle of the facing unit and extend behind wall.

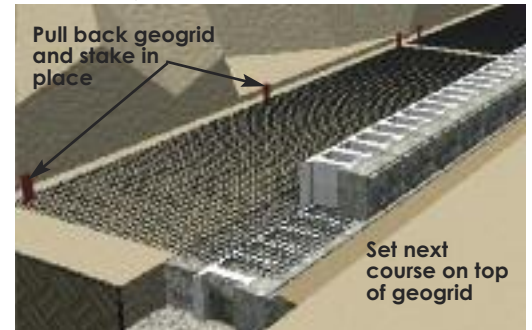

Stake geogrid in place. Install next course of block.

Step 5: Backfill and Compact

- Install wall rock in block cores and 12 in. (300 mm) behind wall. Use approved infill soils to backfill behind the wall rock in the reinforced zone.
- All wall rock and infill soils within 3 ft. (0.9 m) of the wall must be properly compacted using a mechanical plate compactor. **Compact in maximum 8 inch lifts (200 mm)**, this time **starting on the block** and working in a path that runs parallel to the block towards the back of the reinforced zone. Compact all materials to a minimum 95% Standard Proctor.
- Never operate compaction equipment directly on geogrid.
- **All heavy equipment must be kept at least 3 feet (0.9 m) from the back of the wall.** Wall designs typically do not account for surcharges from heavy compaction equipment. Even a properly installed and compacted wall will rotate forward when extreme surcharges from heavy equipment are applied to the top of the wall during construction and final grading.
- Check and adjust for level, alignment and the wall batter as the wall stacks up. It is acceptable to shim under blocks to compensate for a build up of tolerances or an out of level base condition. Asphalt shingles or geogrid work well when shims are required. The maximum allowable shim thickness per course is 1/8 in. (3 mm).
- Remove all excess wall rock and ridges or slag material from the top surface of all AB units. This prepares a smooth surface for placement of the next course. Plate compactors operated on top of the block will remove most slag material and prep the block for the next course. When installing the next course of block, sliding the block into place will also remove any slag material.

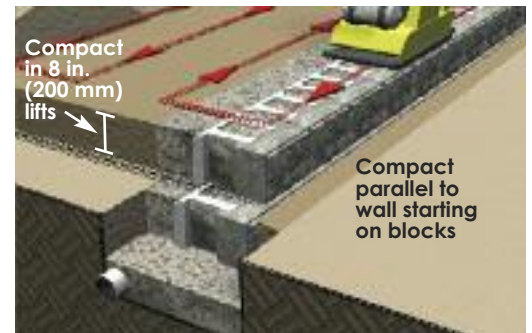

From the second course and up, compact starting on the wall and working to the back of the reinforced zone.

Step 6: Install Additional Courses

- Repeat steps 3 & 4 to complete wall to height required, installing geogrid where needed per the approved plans.
- Use 8 in. (200 mm) of impermeable fill on the last lift to finish off wall.
- See page 46 for information on capping and page 55 for information on ending walls with turn-ins.

AB Fieldstone Construction Tips

Inside and Outside Curves with AB Fieldstone

Building curved and serpentine walls are simple. AB's patented design allows for easy installation of both inside and outside curves. For walls requiring geogrid, see page 58.

- Try to maintain an offset of the vertical seams by at least 1/4 of the block length from the courses below for both inside and outside curves.

Inside Curves

- Place the facing units to form a flowing curve.
- Set anchoring units in place with the back of anchoring units fanned out to form the curve.

Outside Curves

- Place the facing units to form a flowing curve.
- Remove one or both of the wings from the anchoring units to achieve an outside curve. Then set the anchoring units in place.
- See the radius chart to determine the minimum radius for the base course of an outside curve.

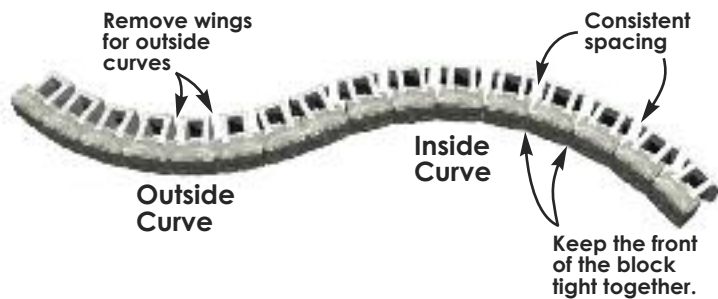

Table 5.1

AB Radius Chart for the Base Course of AB Fieldstone				
Wall Height				
812 facing unit w/SAU (short anchoring unit) 6° (Ref)	4 ft 1.2 m	6 ft 1.8 m	8 ft 2.4 m	10 ft 3.0 m
	6 ft 7 in. 2.0 m	7.0 ft 2.1 m	7 ft 5 in. 2.3 m	7 ft 10 in. 2.4 m

The 824 units are to be used in straight walls or gradual curves only. In tight curve transitions, use 812 units only. Use this chart to find the minimum recommended radius at base of wall. Note all lengths, dimensions and setbacks are approximate.

Modifying Anchoring Units

- Removing the "wings" of the blocks will be needed on projects with curves, corners or step downs. For smooth outside curves, remove one or both of the "wings" from the back of the anchoring units and tighten the radius of the curve. Break wings off with a hammer and chisel in the existing score line to obtain a clean break.
- When working with corners and/or stepping down a wall, split an anchoring unit in half to tie the corner together. Split the block by using a hammer and chisel to make a break down the center of the block.
- On some projects you will need to modify the bottom lip of the block to fit on the course below. Use a hammer and chisel and tap along the lip to remove.

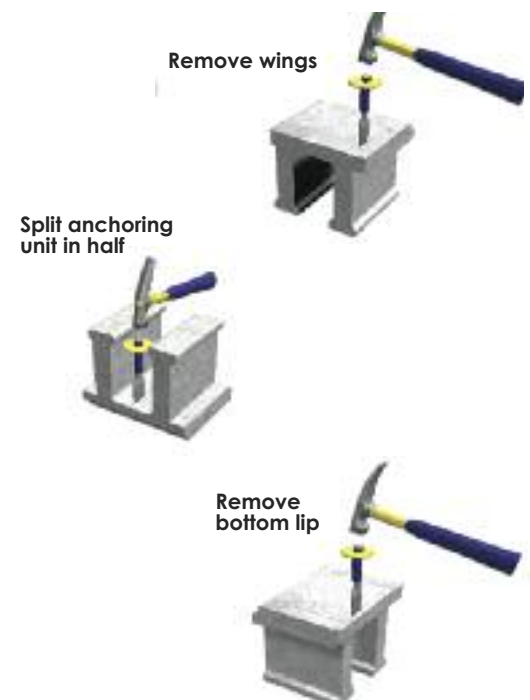

AB Fieldstone Construction Tips



allanblock.com

Inside and Outside Corners with AB Fieldstone

Outside Corners - Some of the AB Fieldstone facing units are manufactured with a textured side that compliments the facing unit. Besides being used as a standard block, these blocks can be used to create a corner. To create a left or right hand corner simply flip the facing unit as needed to change the direction. For walls requiring geogrid, see page 60.

- Whenever possible, begin your wall at the corner. Install a facing unit with the textured end facing out at the corner. Install an additional facing unit perpendicular to create a corner. Install additional facing units in both directions to continue down the wall. Check for level. (Step 1)
- Starting at the corner and working out in both directions, use anchoring units to span the first two facing units in each direction. (Step 2) Both of these anchoring units will need to be modified slightly. On the base course and above remove the wing from one anchoring unit. From course two and above, remove part of the lip off the other anchoring unit so that it fits on top of the course below. (Step 3)
- Use half of an anchoring unit on either side of the spanning anchoring units to get pattern back to each facing unit having its own anchoring unit. (Step 4)
- Align the lip and notch of the anchoring units in each direction to ensure proper placement of next wall course.
- Cut caps at 45 degree angles to complete the outside corner and give the wall a custom finished look.

Step 1



Step 2

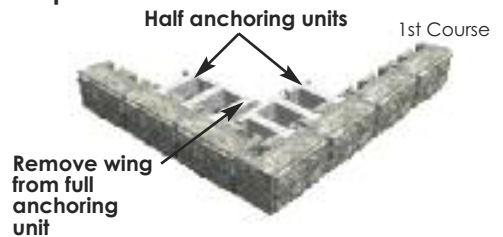

Step 3



Step 4



Outside Corner



Inside Corner

Inside Corners - By alternating the block's placement on each course of the wall, an inside corner can be installed. The 824 facing units are ideal for this task, but 812 facing units are acceptable. For walls requiring geogrid, see page 60.

- To create a 90° inside corner, begin by placing an AB Fieldstone facing unit (A) at the corner. Then lay a second facing unit (B) perpendicular to the first. This second unit (B) must extend past the back of the first facing unit (A). Continue laying out the rest of the base course working from the corner out in both directions. Install the anchoring units.
- On additional courses alternate the placement of the facing units. Remove the lip from the anchoring unit, where the anchoring unit sits on the facing unit below as needed.
- Cut caps at 45 degree angles to complete the inside corner and give the wall a custom finished look.

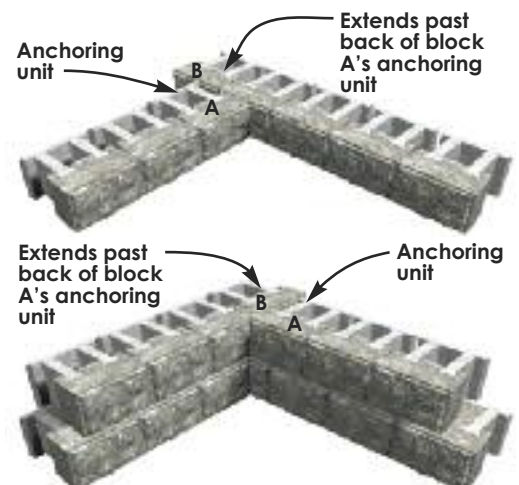

AB Fieldstone Construction Tips

Step Ups and Step Downs with AB Fieldstone

Step Downs - Creating a Step Down is similar to building an outside corner as it uses the same facing units that are manufactured with a textured side and has the same placement of the anchoring units.

- Install the facing units up to the Step Down location. Install the facing unit with the textured end perpendicular to create a corner, with the textured face placed to face out.
- Split an anchoring unit in half. Take one half and remove the bottom lip and place in the facing unit that was used to create the Step Down. See page 49 for details on modifying an anchoring unit.
- The next anchoring unit will be installed in the first two facing unit's that lead up to the Step Down. This anchoring unit will span two facing units. One of the wings of this unit will need to be removed to allow placement.
- Use the other half of the previous anchoring unit in the next slot to get pattern back so each facing unit has its own anchoring unit.
- Use a flexible masonry adhesive to secure the corner units in place.



Modify half an anchoring unit by removing lip to secure the facing unit

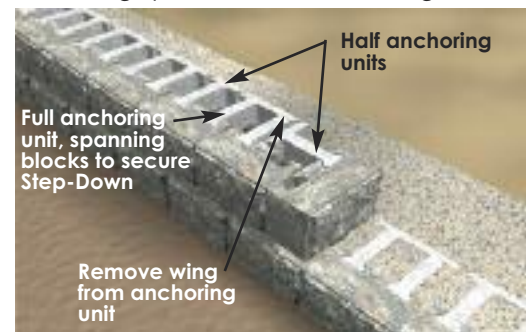

Install the half of an anchoring unit.

Step Ups - When building Step-Ups into a slope, always begin at the lowest wall elevation of the base course. For more information see page 27.

- To create a Step-Up, span a block between the leveling pad and the block course below. Step-Ups are most stable when the upper block has sufficient bearing on the lower block. The length of the 824 assembly (if available) provides the flexibility to make this block ideal for this application. An 812 assembly will work as well.



Create the Step-Up using an 824 unit if available.

AB Fieldstone Construction Tips



allanblock.com

Parapets

Parapets can be built on an existing surface or to finish off the top of a retaining wall. It is now easy to incorporate patio enclosures, fencing or planters with the same product for the entire project.

When building parapets the AB Dogbone unit will be needed along with wall rock to fill the center void between the facing units to provide additional mass and pullout resistance. AB Dogbone units are half the height of the facing units. Two units are needed per 812 facing unit.

AB Dogbone unit

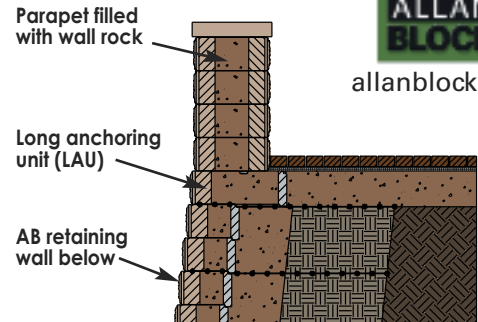

Parapet Widths

Determining the width of the parapet will depend on what function it will perform, but there are two options.

Option A: Standard Parapet - (Opposing facing units attached to each other with the AB Dogbone unit) The AB Fieldstone parapets can be built with a standard width by installing the AB Dogbone units attached to both facing units. This standard width works well for straight walls and to build corners, but cannot accommodate curves. Typically, you will end the standard parapet with a post.

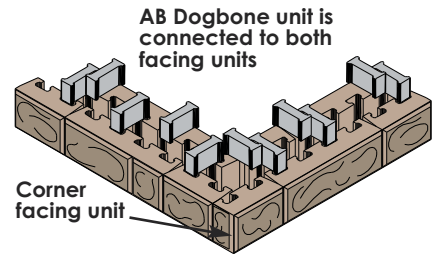

Standard Dogbone Interlocked Parapets with Corners

When building corners, a facing unit will need to be cut for each course to create the corner.

- Install the facing units up to the corner. Place the corner facing unit to create the outside corner.
- The facing unit on the inside will need to be cut to allow for the opposite facing unit to extend in to create the corner.
- Install AB Dogbones and wall rock. AB Dogbone units need to be installed in a staggered placement with the facing unit, one upper, one lower. Place the lower AB Dogbone units (one per facing unit). Backfill the wall rock in 4 in. (100 mm) lifts to allow for staggered placement of the AB Dogbone units. Place upper AB Dogbone units in the opposite side of the facing unit, finish backfilling with wall rock. Two AB Dogbones are needed per facing unit and should have this staggered placement.

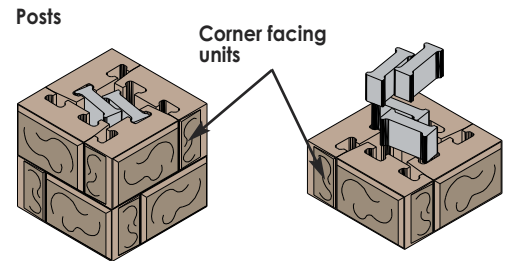
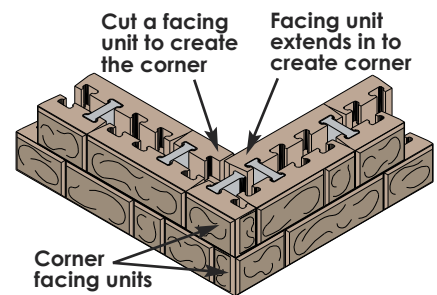

Posts and Standard Dogbone Interlocked Parapets with Posts

Stand alone posts are built using four corner facing units per course. These blocks have a textured side as well as a textured face. Larger posts can be built by adding cut or full length 812 units to each face.

- For Posts, every facing unit needs to have one AB Dogbone unit to secure in place. Fill posts with wall rock in 4 in. (100 mm) lifts to allow for staggered placement of AB Dogbone units.
- For Parapets with Posts. Finish a standard width parapet to post location installing AB Dogbones that connect to both facing units. Install a post at end of parapet panel.
- When building Posts within the wall, the corner facing units do not need to be used where the wall meets the post as the textured side is not visible. Use four corner facing units for each course that exceeds the height of the adjoining parapets.

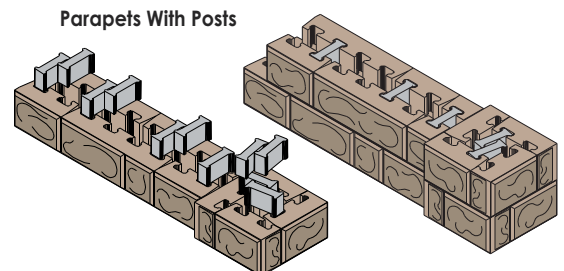

Posts within Parapets

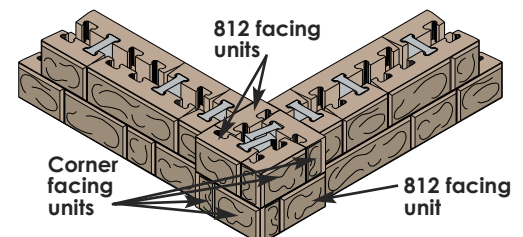

AB Fieldstone Construction Tips

Option B: Wider Parapets or Curved Parapets – This option accommodates any width since the AB Dogbone Units are not connecting the facing units. There are a few widths that make construction easier. A slightly wider parapet that requires no cutting uses two corner blocks to end the wall and works extremely well in straight, corner and curved applications.

Straight Parapets - No Cutting Needed

- Begin by placing the AB Fieldstone facing units on the base material or existing surface. Check for level and alignment.
- Install AB Dogbones and wall rock. Stagger the AB Dogbone units, one up and one down with the facing units to ensure each facing unit has two AB Dogbones securing it in place for every course. Install lower AB Dogbone units first, then backfill with wall rock in 4 in. (100 mm) lifts. Place upper AB Dogbone units, finish backfilling with wall rock.
- Use care when backfilling with wall rock so facing units do not move out of alignment. External jigs or supports may be required.

Wider Parapets - Ending and Corners

To create a wider parapet end with minimal cutting, we recommend using two 812 corner facing units (A) on odd courses and one cut 824 facing unit (B) on the even courses. However, you can create your own parapet width because the AB Fieldstone parapet can be built with custom spacing between to create a wider planter or bar as examples.

Curved Parapets

- When building curved parapets, the parapet must be wider than the standard parapet application because the AB Dogbone units do not line up or attach to both facing units.
- To ensure equal spacing between the facing units remain correct and parallel to each other, level and plumb each course using a tape measure, jig or clamp.
- Stagger the AB Dogbone units, one up and one down with the facing units to ensure each facing unit has two AB Dogbones securing it in place for every course.

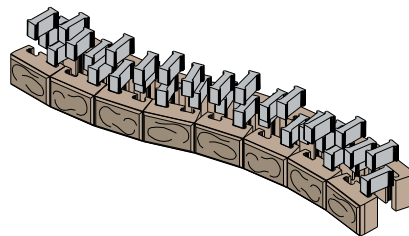
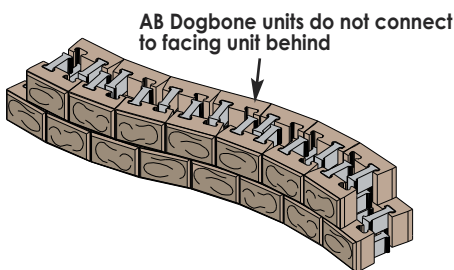
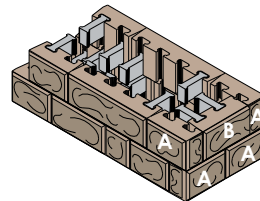
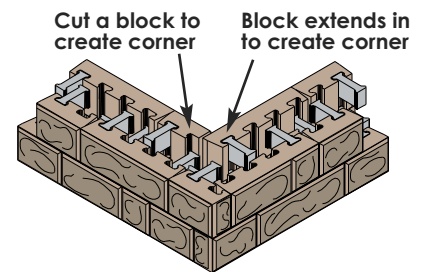
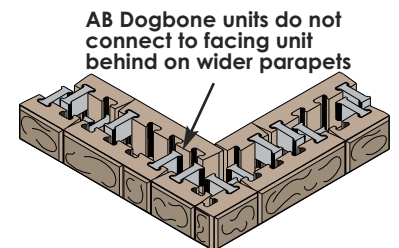
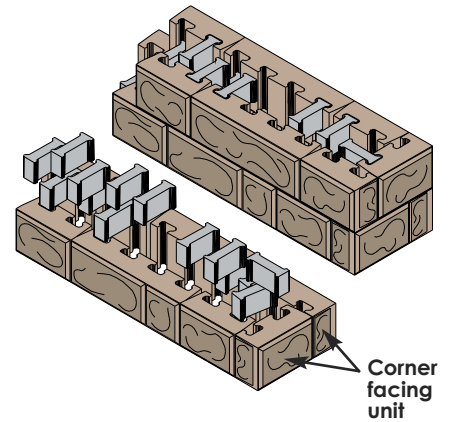

All parapet graphics are to show AB Dogbone placement. All parapet installations need to include wall rock in cores.

Using Multiple Series Faces

What is unique about AB Fieldstone? You can choose from different facing options to match or compliment your natural surroundings. Every facing unit is created to emulate the look and feel of natural stone. By then blending the series faces together you can create your own perfect look and style.



Colonial and Sierra faces blended together.

CONSTRUCTION DETAILS



allanblock.com

Expanded details on building with Allan Block.

Finishing Walls	55
Curves	56
Curves with Geogrid	58
Corners	59
Corners with Geogrid	60
Stairs	61
Terraces	63
Design Details	65
Construction and Inspection Checklist	67
Material Estimate Worksheet	69
Geogrid and No-Fines Estimating Charts	72

Finishing Walls

Ending and Topping Off Walls

Allan Block offers a great variety of finishing options for the wall.

Mulches: Allan Block's patented raised front lip provides a built-in edging for landscape rock, mulch, grass or soil.

AB Capstones: AB Capstones can be used to finish off the top of a wall. Use a high grade, waterproof flexible masonry adhesive to secure AB Capstones in place.

See allanblock.com for information on cutting AB Capstones for curves or corners.



Mulch or Soil



AB Capstones



AB Capstones with step ups

Building Step Downs

Walls with step downs can be easily finished by adding a AB Lite Stone, or turning the ends back into the hillside. For tips with patterned wall Step Downs, see page 40.

Our recommendation for a gradual step-down is using the AB Lite Stone.



For a full course step-up, use the AB Corner Block.

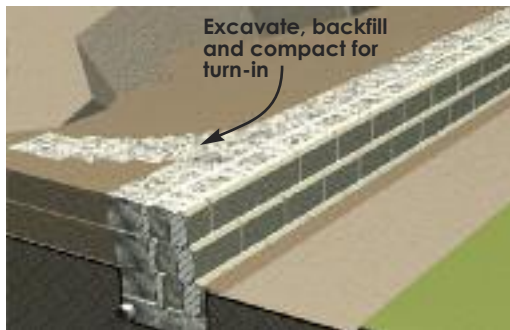

Building Turn-Ins

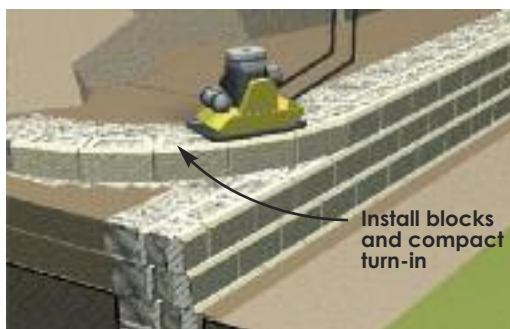

Building Turn-Ins

For a graceful, flowing end to the wall, curve the wall to create a plantable area that can soften the look of the wall.

When building a turn-in, a base trench will need to be excavated, backfilled and compacted, the same as the base course of blocks.

Proper backfilling and compaction is important, where the wall turns back into the slope. To ensure the turn-in area doesn't settle differently than the rest of the wall, make sure the entire area below the new base is compacted thoroughly.

Flowing turn-in of wall



For a step-down that doubles as a planter, turn the wall in 2 or 3 blocks after the AB Corner Block.



For a natural flow into the landscape, curve the wall back into the hillside.



Construction Details - Curves



allanblock.com

Building curved and serpentine walls is simple. AB's patented design allows for easy installation of both inside and outside curves.

Most curves can be built with no cutting involved.

- Try to maintain an offset of the vertical seams by at least $\frac{1}{4}$ of the block length from the courses below. Cutting a block in half or using the half width blocks, will assist in creating a proper offset.
- Before beginning construction, review the plans and layout the wall to eliminate tight radii. More gentle sweeping curves produce more aesthetically pleasing walls. See page 57 for the radius chart.
- Use blocks with lower setbacks or half width blocks on curves for smoother transitions.

Inside Curves

- To build a flowing inside curve, butt the block end to end to match the smooth curve required on the project. Try to keep spacing consistent between the backs of the blocks.

Outside Curves

- To build smooth outside curves, remove one or both of the "wings" from the back of the blocks and tighten the radius of the curve. Break wings off by tapping on the back of the wing to obtain a clean break.

Tighter Curves

- Using full size blocks in tight curves will create a gap between the courses. For cleaner lines, it may be necessary to remove parts of the bottom notch to fit the blocks closer together.

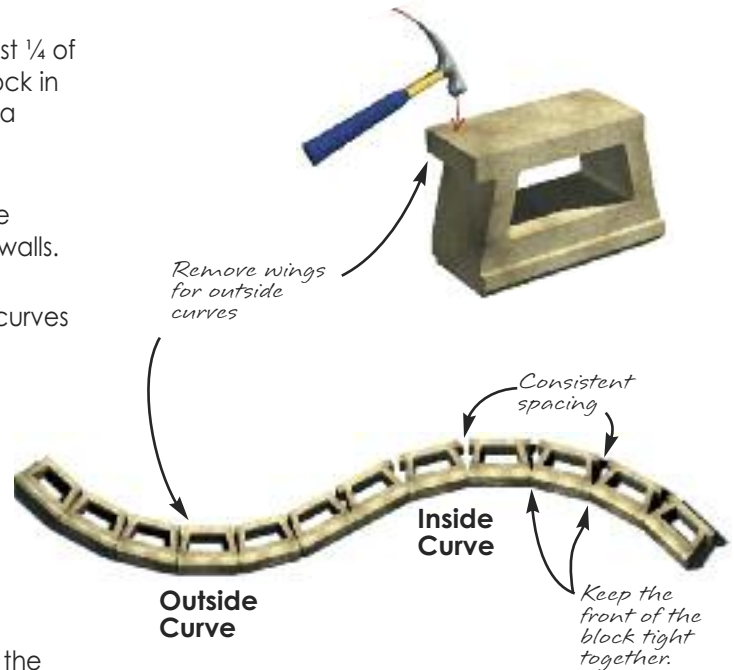

Cutting The Bottom Notch For Tighter Inside Curves

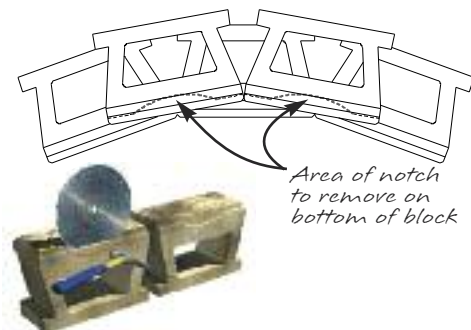

Cutting The Bottom Notch For Tighter Outside Curves

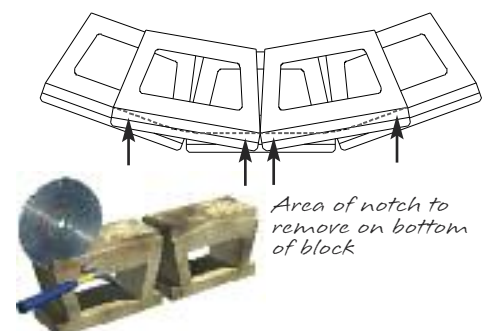

Working with Radii

- Refer to Table 6.1 to confirm that the AB product you are using will accommodate the desired wall radius.
- The tightest or smallest radius at the top of any AB wall using full size block is 4 ft. (1.2 m), and 2.5 ft. (0.8 m) using the half width blocks. The final height of the wall will determine what the minimum radius at the base course must be. The wall creates a coning effect as it is stacked up, creating the need for a larger radius at the base course. Use the **Radius Chart** to determine what the radius of the base course of the wall needs to be, so the top course of the wall will not be less than 4 ft. (1.2 m).

Starting a Radius

From the point of where the curve will start, measure straight back from the wall the required amount (shown in the Radius Chart) and drive a stake into the ground. This will be the center of the curve. Attach a string line to the stake the length of the radius and rotate it around to mark the location of the base course. Install the blocks with the front of the blocks lining up with the mark.

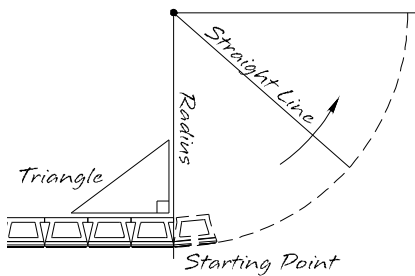

- To transition the curve back into a straight wall or another curve, lay out the curve and the first couple blocks of the next section. Adjusting 1 or 2 of the blocks will help in the transition of the next section of wall.



For a smooth curve with less cutting, use our half width blocks to help build the curve.

Base Course Radius for an outside curve on a 4 ft tall 6° wall

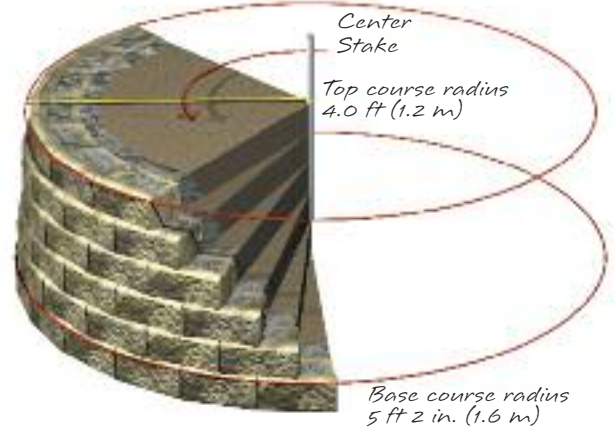

Table 6.1

Setback	AB Radius Chart for the Base Course			
	Wall Height			
AB & AB Europa Collection Full Size Blocks	4 ft 1.2 m	6 ft 1.8 m	8 ft 2.4 m	10 ft 3.0 m
3° (Ref)	4 ft. 9 in. 1.43 m	5.0 ft 1.52 m	5 ft. 4 in. 1.6 m	5 ft. 8 in. 1.7 m
6° (Ref)	5 ft. 2 in. 1.6 m	5 ft. 6 in. 1.7 m	5 ft. 11 in. 1.8 m	6 ft. 4 in. 1.9 m
12° (Ref)	5 ft. 6 in. 1.7 m	6.0 ft 1.8 m	6 ft. 6 in. 2.0 m	7.0 ft 2.1 m
AB Fieldstone Collection 812 facing unit w/short anchoring unit (SAU)	4 ft 1.2 m	6 ft 1.8 m	8 ft 2.4 m	10 ft 3.0 m
6° (Ref)	6 ft. 7 in. 2.0 m	7.0 ft 2.1 m	7 ft. 5 in. 2.3 m	7 ft. 10 in. 2.4 m
AB & AB Europa Collection Half Size Blocks	2 ft 0.6 m	4 ft 1.2 m	6 ft 1.8 m	
6° (Ref)	3.0 ft 0.9 m	3 ft. 5 in. 1.0 m	3 ft. 10 in. 1.15 m	

Use this chart to find the minimum recommended radius at base of wall. Note all lengths, dimensions and setbacks are approximate.

Construction Details - Curves with Geogrid



allanblock.com

Inside Curves

Geogrid needs to have 100% coverage around an inside curve. To achieve this, additional layers need to be installed either above or below the course where the grid is required to fill voids that are created.

- Cut geogrid to required lengths per the approved plan.
- Lay out the primary geogrid around the curve butting front edges together. Make sure strength direction runs perpendicular to wall face. Mark the blocks or take note of the areas where there are voids in the grid placement.
- Place the filler piece of grid on the next course (or the course below) to cover the void left on the primary layer.

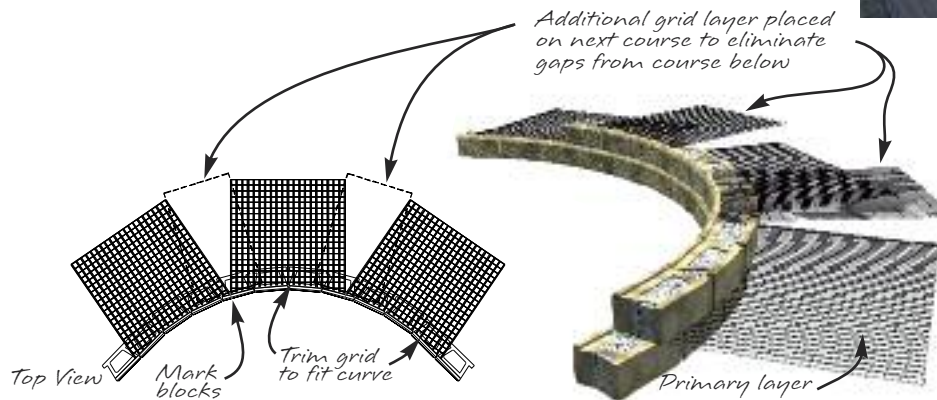

Outside Curves

- Cut geogrid to required lengths per the approved plans.
- Lay out the geogrid around the curve.
- Lift the section of grid that overlaps and place the fill material to separate. Grid layers need to be separated by a 3 in. (75 mm) layer of approved fill material.
- Never compact directly on the geogrid.

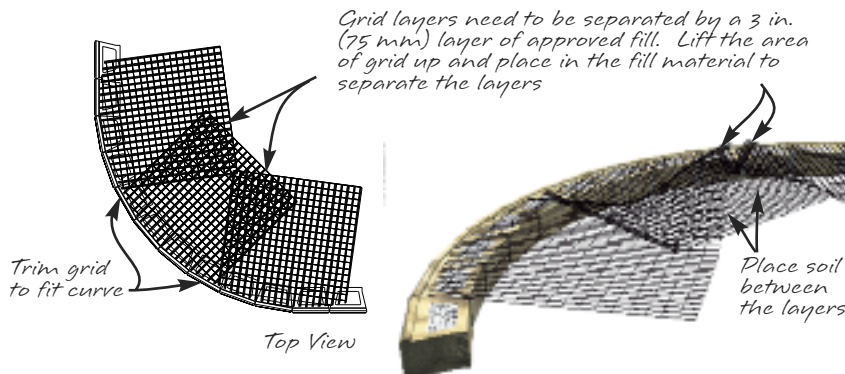

Construction Details - Corners

Inside Corners

AB Blocks are easily modified to build inside corners. To construct an inside corner, you will remove part of the raised lip on one block on each course.

- Use a saw with a diamond blade or a chisel to remove half of the raised front lip. This allows the next course to be installed on a level surface (Step 1).
- Lay the modified block perpendicular to another AB unit. This creates the corner (Step 2).
- On the next course, remove *the opposite half* of the lip of an AB unit and position it over the right angle corner (Step 2).
- On each successive course, simply reverse the position of the modified block to obtain an interlocked corner.

Step 1



Step 2



Remove part of front lip so next course will seat properly

Remove notch to form corner



Area of front lip removed

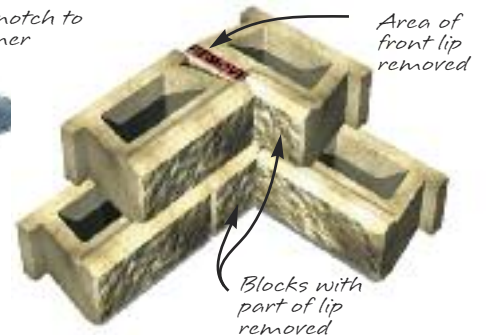

Blocks with part of lip removed

Outside Corners

AB Corner Blocks are used to build outside 90° corners. To construct an outside corner, you will use an AB Corner Block on every course, alternating a right and left hand corner for each course. Additional corner construction information can be found at allanblock.com.

- Start construction of all walls at the corner. This will keep the block alignment within the 3 in. (75 mm) overlap required.
- Place an AB Corner Block at the corner. Place AB Blocks to build the base course working out from the corner in both directions (Step 1). Level, backfill and compact.
- On the 2nd course place an alternating AB Corner Block. Again work out from the corner in both directions. Level, backfill and compact (Step 2).
- Repeat this procedure, alternating every other course with AB Corner Blocks. Leveling, backfilling, and compacting as the wall grows (Step 3).

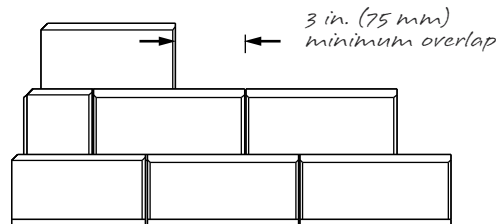

Step 1

Ensure base is level going both directions



Step 2



Step 3



Altering AB Corner Blocks for Different Setbacks

AB Corner Blocks are manufactured with a 12° setback. With some minor adjustments, the blocks can be modified to work with any setback. To modify the block for a 6° setback, cut a notch on the short side of the block 0.75 in. (20 mm) deep.

For a 6° setback, make a horizontal cut 0.75 in. (20 mm) deep



Remove this piece after cut is made

Construction Details - Corners with Geogrid



allanblock.com

Installing Geogrid on Inside 90° Corners

On inside corners additional geogrid is required to extend past the end of the wall, 25% of the completed wall height ($H/4$).

- Cut geogrid to required lengths per the approved plan. As a general rule the length of the geogrid needs to extend a minimum of 25% of the wall height past the end of the inside corner.
- Install the layer of geogrid with the geogrid extending past the inside corner.
- Alternate the next layer of geogrid to extend the past the inside corner in the opposite direction.

EXAMPLE:

Finished wall height is 12 ft. (3.7 m), divide by 4 which equals 3 ft. (0.9 m).

The length the grid will need to extend past the corner is 3 ft. (0.9 m).

Geogrid with Inside 90° Corners

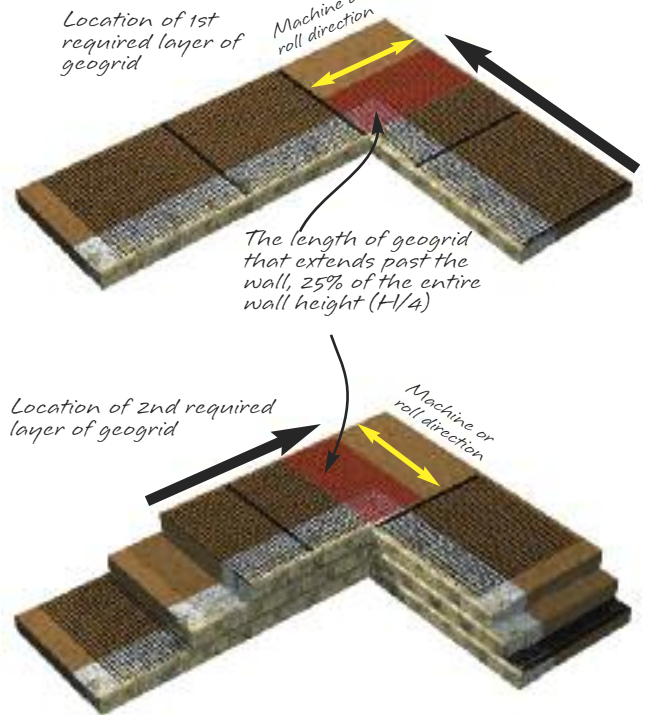

Geogrid with Outside 90° Corners

Installing Geogrid on Outside 90° Corners

Geogrid must always be installed with its strong direction perpendicular to the face of the wall. To accomplish this with 90° outside corners:

- Cut geogrid to required lengths per the approved plans.
- Install geogrid to the outside corner with the roll direction running back into the excavated site.
- On the next course of block, lay the next layer of grid perpendicular to the previous layer.

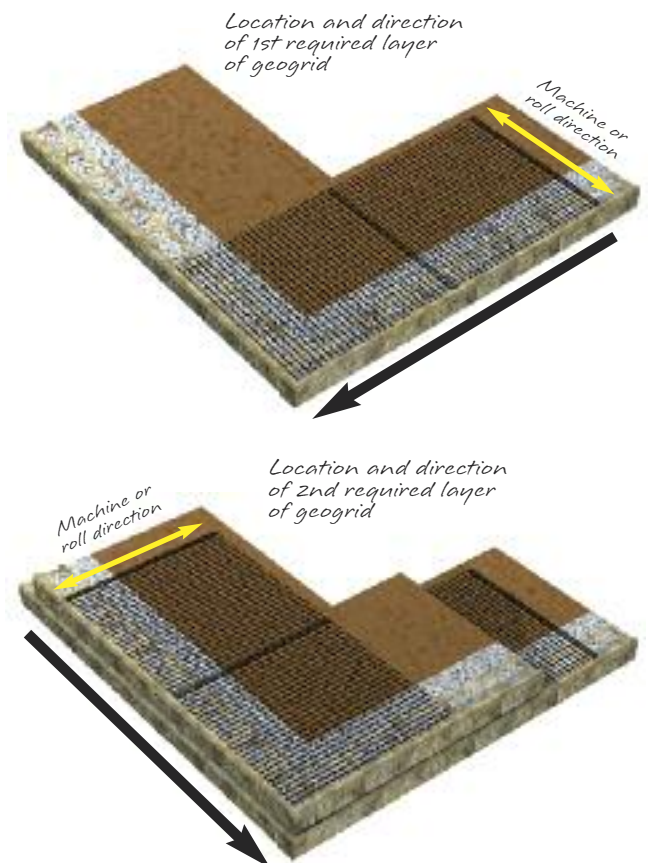

Construction Details - Stairs

Basic Stair Construction

Always check local code requirements before building any type of stair application. The steps below are general guidelines for building stairways. By understanding the basic installation elements, stairways can be easily incorporated into the wall installation.

- Before excavation can begin, the rise and run of the stair treads must be determined and code requirements must be met. With that information, the entire base trench can then be excavated. Some examples of different stair tread options are illustrated below.

Our example here uses a base trench of 6 in. (150 mm) and a stair tread of AB Capstones and pavers.

- Excavate to the necessary depth and width for each stair riser and **thoroughly compact the entire area** to 95% Standard Proctor with a mechanical plate compactor.
- Check for level.
- Starting at the first step, fill the base trench with 6 in. (150 mm) of wall rock. Rake smooth.
- Compact and check for level. **Stairs need extra compaction to avoid any settling later.** Better compaction is achieved by backfilling and compacting in 4 in. lifts (100 mm) or less when able.
- Install blocks on the base material. Allow for a space of at least 6 in. (150 mm) behind the blocks for wall rock.
- Adjust for level and alignment of each block as it's installed.
- Install wall rock in the block cores, fill any space in front of and behind the block. When backfilling behind the blocks, fill the entire area that was earlier excavated to create the base for the next stair riser. This should produce a level base for the next set of risers. We recommend backfilling and compacting behind the block in 4 in. lifts (100 mm) to achieve better compaction when able.
- Rake wall rock smooth and compact with the first pass of the compactor directly on the tops of the block and then working in a path that runs parallel to the block. Compact to 95% Standard Proctor.
- Repeat this process for each additional course of steps needed.

Excavate for stairs and compact.

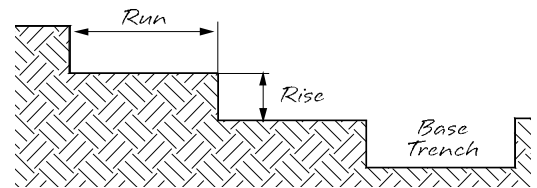

Install and level blocks on base material.

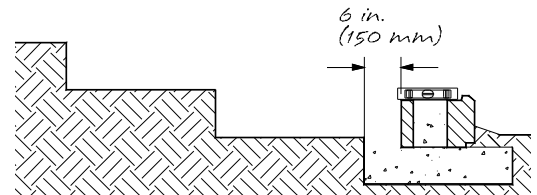

Backfill block cores and behind block with wall rock. Compact.

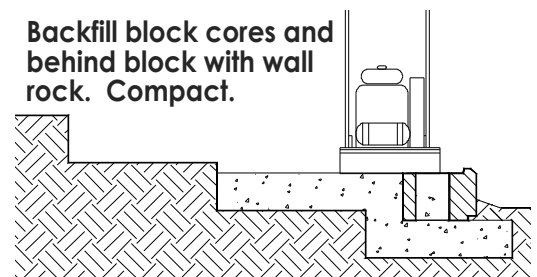

Install next stair course.

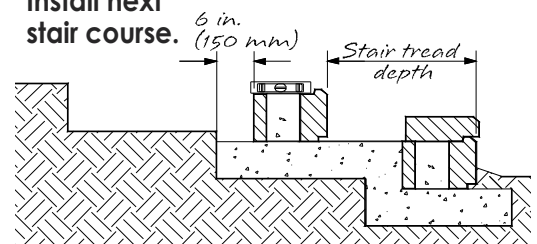

Continue for each new stair.

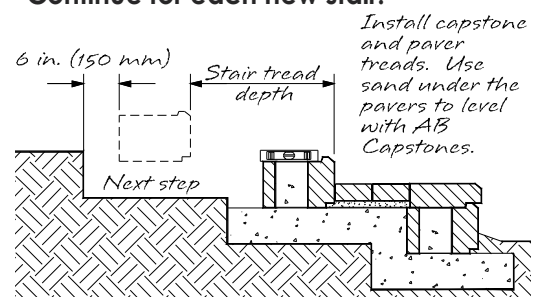

Stair Tread Options





allanblock.com

Stairs can be designed with flowing curves or straight lines. Curved sidewalls create a softer, natural look. Straight sidewalls and corners offer a crisp, traditional style; however they require AB Corner Blocks and take more time to build.

Allan Block's patented front lip provides a built-in edging that works well when installing the stair tread material. Allan Block Capstones, pavers, poured concrete, crushed rock, mulches and flagstone are good stair tread examples. Ensure that stair treads are secured in place for safe use.

Additional stair designs and technical information explaining the construction process is available on our website at allanblock.com or from your local Allan Block representative.

Remember to always check with the local codes before construction.

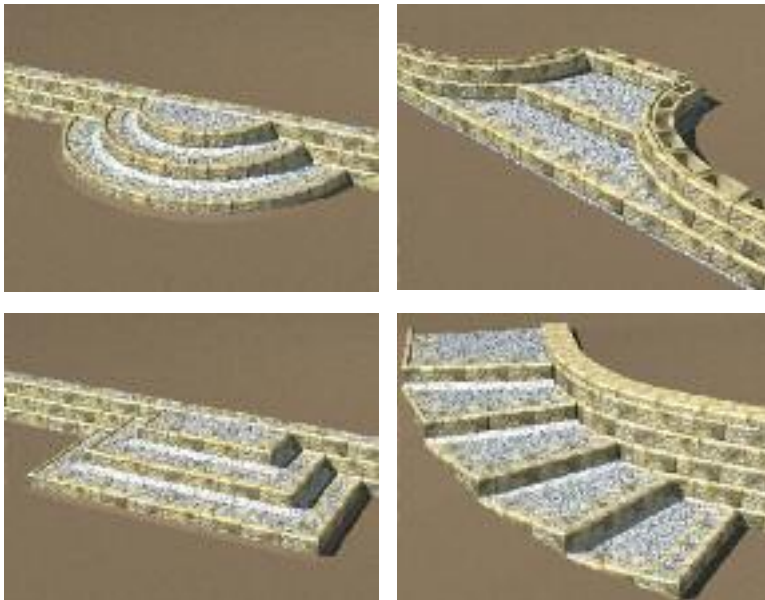

How Many Steps?

To find the number of steps needed, measure the total rise of your slope in inches (mm) and divide by 8 in. (200 mm) which is the height of a step.



CONSTRUCTION DETAILS

Construction Details

Terraces

It is often more aesthetically pleasing to replace one large retaining wall with two or more smaller terraced walls. Terraced walls can act as surcharges and may create global instability, therefore reinforcement may be necessary. Always check with a local qualified engineer when building terraces.

Walls perform **independently** and may not need engineering when the distance between gravity walls is at least two times the height of the lower wall, and the height of the upper wall is equal to or less than the height of the lower wall. Use the Gravity Wall Chart on page 13 to determine if geogrid is required or check with a local wall engineer.

Walls that must be **evaluated by an engineer** are any walls needing geogrid reinforcement, walls closer than two times the height of the lower wall, walls with more than two terraces, and terraced walls with any structures above.

Terraced walls that do not perform independently must also be evaluated for global stability, and the lower walls must be designed to resist the load of the upper walls.

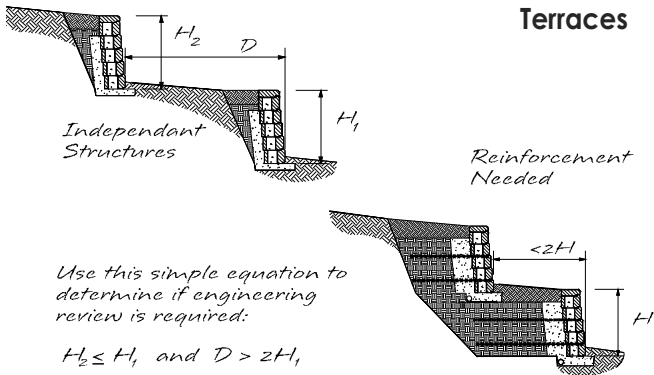

Water Applications

Retaining walls constructed in conditions where there is moving water (streams), standing water with wave action (lakes), or retention ponds are considered water applications.

Water applications must be evaluated and designed to fit the unique characteristics of the site. Consult with a local qualified engineer for design assistance.

Water Application

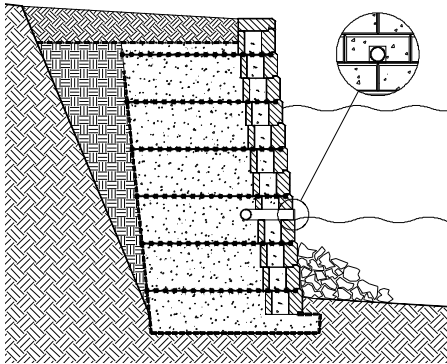

Fences/Guide-Rails

There are several options for installing fences and guide rails on top of an Allan Block wall. The structure and wind loads of the materials used will determine the placement of the fence relative to the AB wall and if additional reinforcement is required. Refer to the approved plans for construction details.



Lighting

Allan Block's hollow core design makes it easy to install lighting. Cut a hole in the location where the light will be to accommodate the wiring and attachment of the light to wall face. Carefully follow the manufacturer's instructions for lighting and electrical installation, as various fixtures may be assembled differently. Always check local building codes for electrical installation requirements.



Design Details

All drawings are for information only and not for construction. See the approved plans for exact details or contact the local engineer of record for written guidance. See allanblock.com for additional details and information.

Typical Reinforced Wall Application

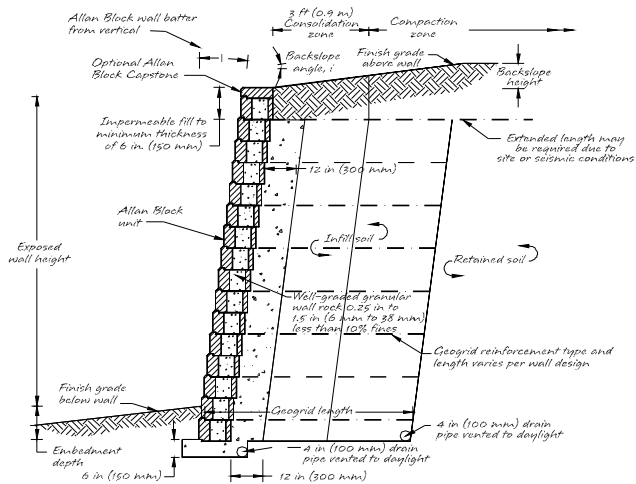

Typical Gravity Wall Application

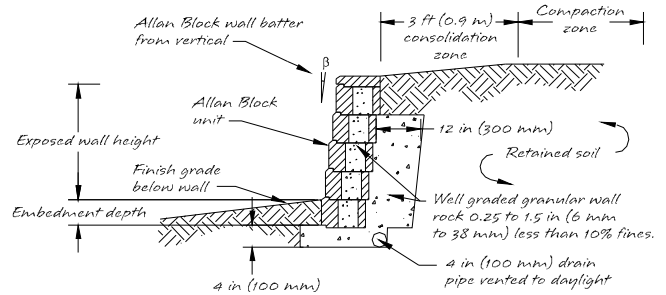

Typical Water Application

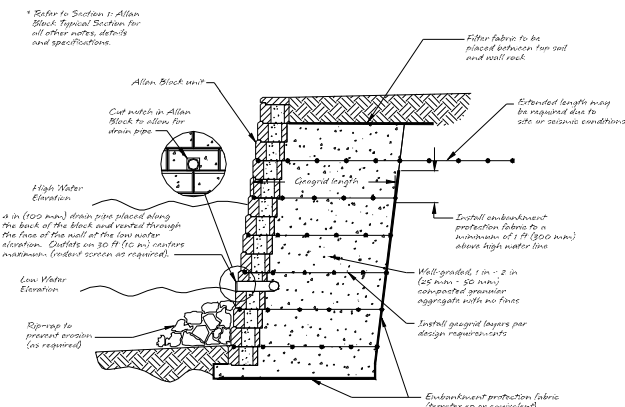

Swales

* Refer to design details Section 1: Allan Block Typical Section for all other notes, details and specifications.

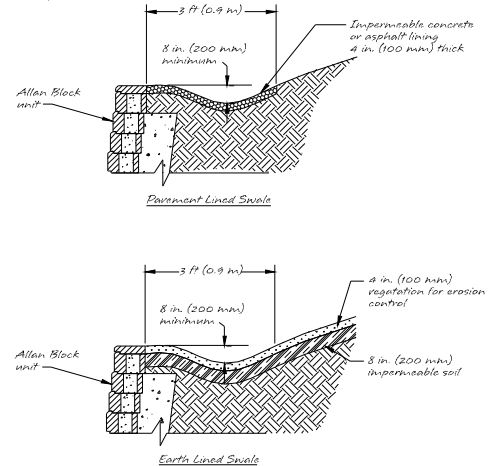

Chimney Drain and Blanket Drain

* Refer to design details Section 1: Allan Block Typical Section for all other notes, details and specifications.

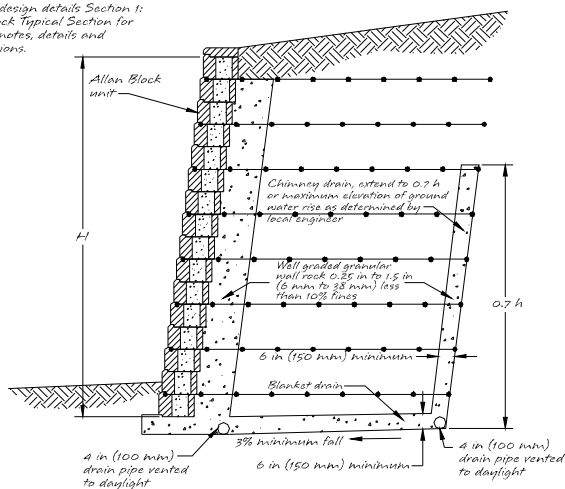

Alternate Drain

* Refer to design details Section 1: Allan Block Typical Section for all other notes, details and specifications.

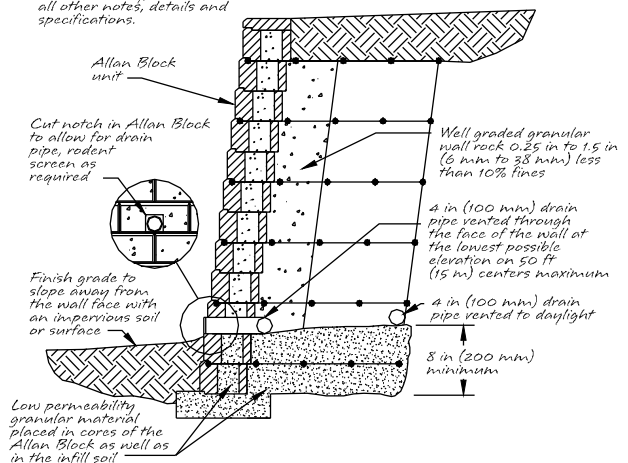

Wind Bearing Fence or Railing, Option 1

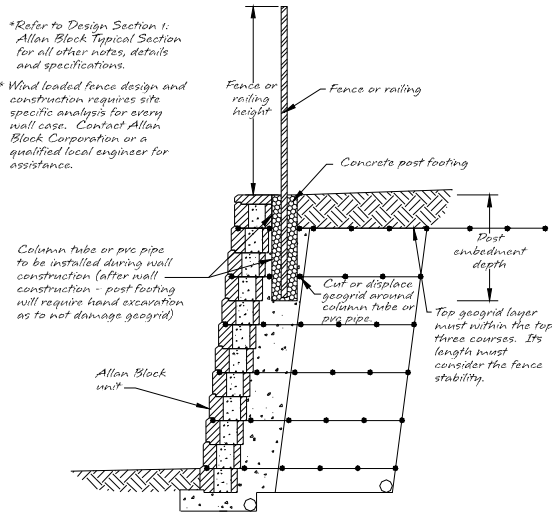

Wind Bearing Fence or Railing, Option 2

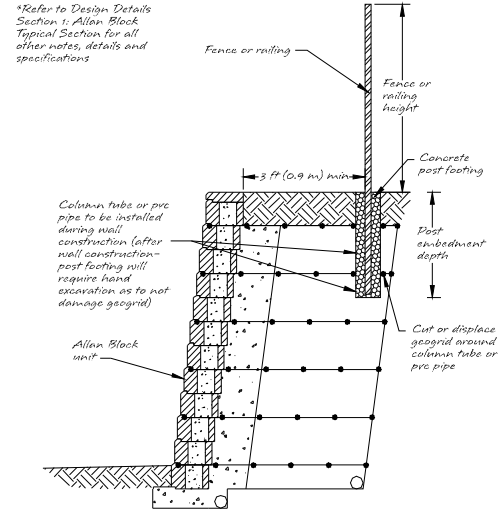

Non-Wind Bearing Fence or Railing

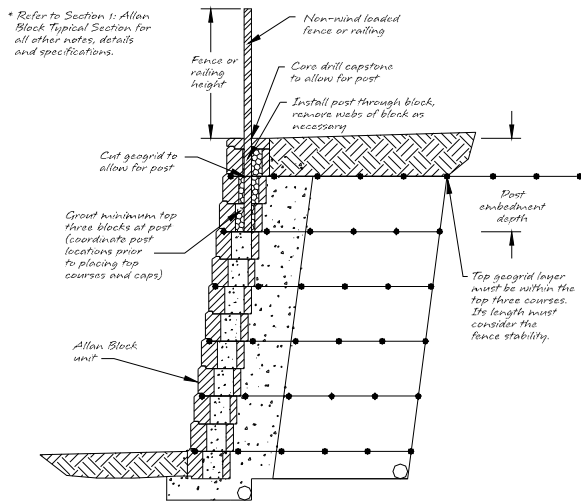

Double Wall Parapet

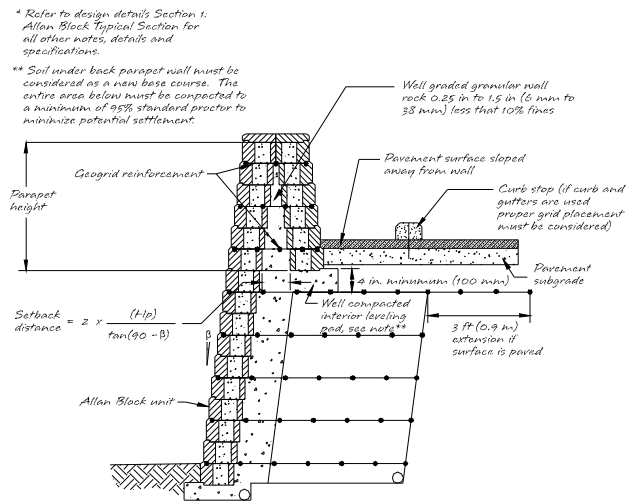

Impact Barrier

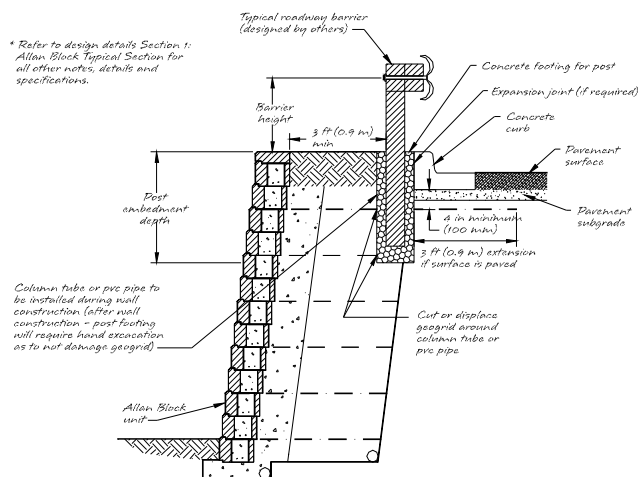

Non Impact Rail

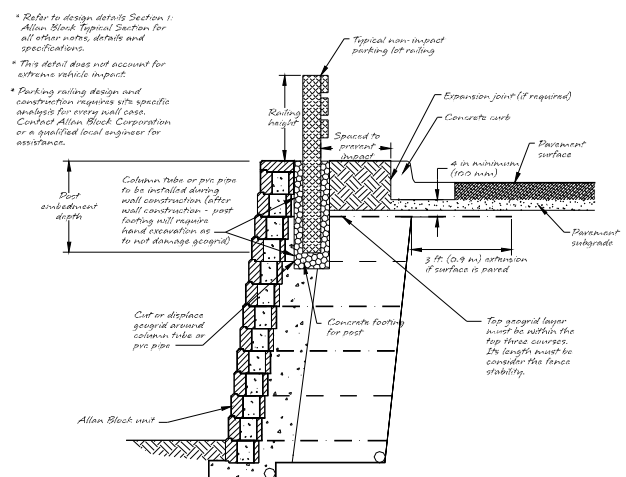

Construction and Inspection Checklist

To ensure that the basics of the retaining wall project are covered, use the following construction and inspection checklist. For a thorough procedure use this list as a guide to prepare your project specific checklist and to review the most common points. It may also be used during the bidding process or a pre-construction meeting to ensure that all special provisions are complied with. Always check the local building codes, document any changes to the plan in writing, and notify the wall design engineer with any concerns on water management.

Typical Reinforcement Cross Section

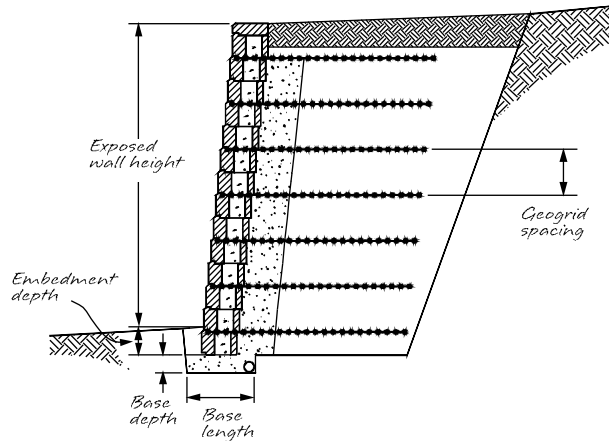

Review wall design plans for:

A. Compliance of site to latest site plan

- Does the site plan and wall layout coincide with current site conditions?
- Have all slopes above and below the walls been taken into account on the plans?
- Do the section drawings match the topography of the job-site?
- Have site utilities been accounted for?
- Are there any recommendations for changes to the site plans to accommodate the wall?

B. Review of reported soil conditions with on-site soils engineer

- Are on-site soils consistent with soil parameters used in wall design?
- Does the site show indications of multiple types of soil, and has this been accounted for?
- Is there evidence of landfill areas on site?
- Has the owner contracted with a geotechnical engineering firm for overall / global stability outside the wall design envelope (H tall by the greater of 2H or $H_e + L$ long)?

C. Review of above-grade water management with project civil engineer

- Has surface runoff been accounted for in the site design?
- Will this site be irrigated?
- If storm drains become inoperable where will the water migrate to?
- During renovation of land will temporary drainage be an issue?



D. Review of below grade water management with wall design engineer and general contractor

- How and where will drain pipe be installed?
- Is it possible to vent drain pipe to daylight?
- Is venting to a storm drainage system an option?
- Will outlets be located and protected from blockage or damage?

E. Surcharges

- Have all surcharges been accounted for?
- During construction are there any temporary surcharges that should be accounted for?

Review Construction Details And Procedures:

- _____ **A.** Mark station points for top and bottom of wall elevation and change in wall direction.
- _____ **B.** Identify changes in grid lengths, location of grids, and types of grid to be used.
- _____ **C.** Determine and locate proper base size for each section of wall.
- _____ **D.** Verify that the correct type and color of block has been ordered and delivered to the job.
- _____ **E.** Verify that the foundation soil and retained soil conform to design requirements.
- _____ **F.** Verify that infill soil meets design standards.
- _____ **G.** Verify that compaction testing will be performed, who is responsible, at what intervals of locations along the wall, and what coordination will be required.
- _____ **H.** Determine what method will be used to verify construction materials, methods, and sequence of construction. (ie: written documentation of as built, full time inspector on site, photographic documentation.)
- _____ **I.** Wall contractor is responsible for quality control of wall installation per the approved plans. The owner or owner's representative is responsible for engineering and quality assurance of the project.

Additional Notes:

Material Estimation Worksheet

Order Materials

Blocks: Ordering block is easy. Use the following steps or visit allanblock.com for helpful estimating tools.

Total LENGTH of wall(s) ft. (m)	divided by (÷)	WIDTH of the block ft. (m)	equals (=)	Blocks per course
				multiply (x)
Total HEIGHT of wall(s)* ft. (m)	divided by (÷)	HEIGHT of block ft. (m)	equals (=)	Courses in wall
				equals (=)
				Blocks needed**

Notes:

* Wall height needs to have the amount of buried block included. Buried block should be a minimum of 6 in. (150 mm) or 1 in. (25 mm) for each 1 ft. (0.3 m) of wall height. See the approved plans to find out what the final height including the buried block will be.

**Extra blocks will need to be included if walls have step ups and/or stairs. Ordering an extra 5% is always recommended to account for any problems during construction.

- See your local Allan Block dealer for exact block dimensions, which need to be used when estimating blocks.

Base and Consolidation Zone: Allan Block recommends using the same material for the base, within the block cores and behind the blocks. A well-graded (balanced mix of grain sizes) compactible aggregate, 0.25 in. to 1.5 in. (6 mm to 38 mm) diameter with less than 10% fines is needed. Check your local aggregate sources for availability.

These estimates use the minimum amount of material required to build a wall. See the approved plans for exact amounts.

A). Base: The minimum base for a geogrid reinforced retaining wall is: 2 ft. (0.6 m) wide x 0.5 ft (0.15 m) high.

Calculate:

$$\frac{2 \text{ ft. (0.6 m)}}{\text{Width of base}} \times \frac{0.5 \text{ ft (0.15 m)}}{\text{Height of base}} \times \frac{\text{Length of wall}}{\text{ft. (m)}} = \frac{\text{Wall Rock}}{\text{ft}^3 \text{ (m}^3\text{)}}$$

Convert cubic feet (cubic meters) to tons by:

$$\frac{\text{Wall Rock}}{\text{ft}^3 \text{ (m}^3\text{)}} \times \frac{120 \text{ lbs/ft}^3 \text{ (1,923 kg/m}^3\text{)}}{\text{Unit weight of rock}} \div \frac{2000 \text{ lbs/ton (1000 kg/ton)}}{\text{Unit weight of rock}} = \frac{\text{WALL ROCK IN TONS}}{\text{WALL ROCK IN TONS}}$$

B). Block Cores and Consolidation Zone: This includes the material in the block cores plus a 12 in. (300 mm) layer behind the blocks.

Calculate:

$$\frac{\text{Wall height}}{\text{ft. (m)}} \times \frac{\text{Wall length}}{\text{ft. (m)}} \times \frac{1.4 \text{ ft. (0.43 m)}}{\text{Wall Rock}} = \frac{\text{Wall Rock}}{\text{ft}^3 \text{ (m}^3\text{)}}$$

Convert cubic feet (cubic meters) to tons by:

$$\frac{\text{Wall Rock}}{\text{ft}^3 \text{ (m}^3\text{)}} \times \frac{120 \text{ lbs/ft}^3 \text{ (1,923 kg/m}^3\text{)}}{\text{Unit weight of rock}} \div \frac{2000 \text{ lbs/ton (1000 kg/ton)}}{\text{Unit weight of rock}} = \frac{\text{WALL ROCK IN TONS}}{\text{WALL ROCK IN TONS}}$$

C). Add the totals from A & B together:

Total WALL ROCK

Define Terms



allanblock.com

Base Material - A base pad of granular material, compacted and leveled to receive the base course of AB units.

Reinforced Zones - Area located directly behind the block that runs to the end of the area being reinforced by any geogrid reinforcement material.

Consolidation Zones - The 3 ft. (0.9 m) area directly behind the back of the block and extending toward the back of the excavated area.

Compaction Zones - The area located behind the consolidation zone that runs to the end of the area being disturbed by any construction activities.

Geogrid - A manufactured high strength reinforcement grid material that comes in rolls of various sizes and strengths.

Infill Soils - The soil used to backfill behind the wall rock in the reinforced zone. These soils need to be identified and approved by a qualified engineer before they can be used. A granular type of material is best.

Drain Pipe - Used to direct incidental water that makes its way in behind the reinforced mass, and vents it to daylight by creating a channel for the water to flow out from.

Wall Rock - Compactible aggregate ranging in size from 0.25 in to 1.5 in. (6 mm to 38 mm) with no more than 10% fines. Used for base material, within block cores and behind the block.

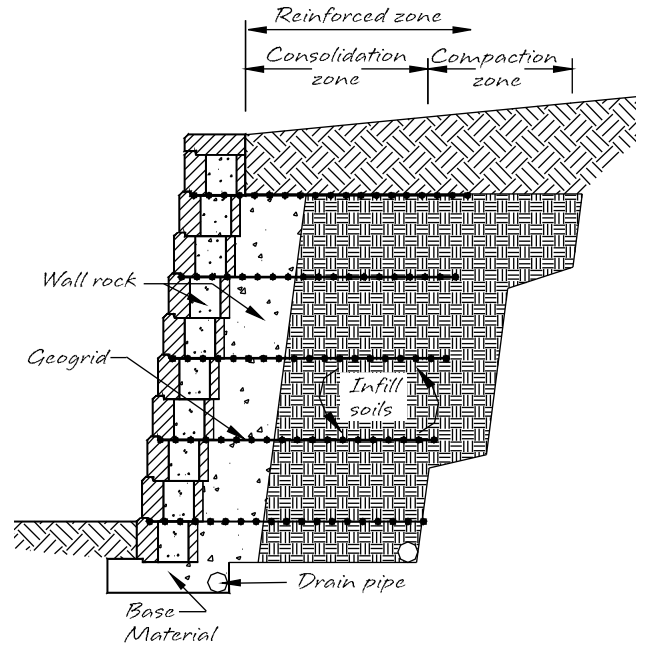

Geogrid

Using the approved plan, contact your local geogrid supplier or Allan Block Representative for geogrid specifications and assistance in ordering materials.

Drain Pipe

The length of the wall will usually determine the same amount of drain pipe needed. Check the approved plan for exact specifications and locations of the drain pipe.

Infill Soils

Using the approved plan, subtract 2 ft (0.6 m) from the grid length required. This figure will determine the depth for the infill soils. (1 ft (0.3 m) for the block and 1 ft (0.3 m) for the wall rock behind the block)

$$\frac{\text{_____ ft. (m)}}{\text{Depth area}} \times$$

$$\frac{\text{_____ ft. (m)}}{\text{Height of wall}} \times \frac{\text{_____ ft. (m)}}{\text{Length of wall}} \times \frac{120 \text{ lbs/ft}^3 (1,923 \text{ kg/m}^3)}{\text{Unit weight of rock}} \div \frac{2000 \text{ lbs/ton} (1000 \text{ kg/ton})}{\text{_____ kg/ton}} = \text{Infill soil}$$

AB Capstones

$$\frac{\text{_____ ft. (m)}}{\text{Wall length}} \div \frac{\text{_____ ft. (m)}}{\text{Width of capstone}} = \text{AB Capstones needed}$$

Adhesive for Capstones

Use one 29 ounce tube (820 gm) of adhesive for every 60 ft. (18 m) of wall length where capstones will be installed.

Geogrid and No-Fines Concrete Estimating Charts

These pre-engineered tables provide an accurate **estimate** for geogrid reinforcement and no-fines concrete. To use the tables, follow these simple steps:

- 1) Verify that the site condition of your retaining wall matches the table being used.
- 2) Verify that the soil conditions at your site match the description given.
- 3) Choose the wall height needed for your site and read across to find the number of grid layers, embedment length, grid locations or concrete depth.
- 4) Verify that excessive water runoff, or a high water table, is not present.

Case A

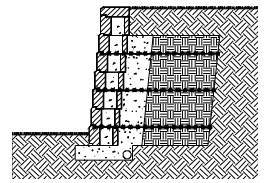

Case B

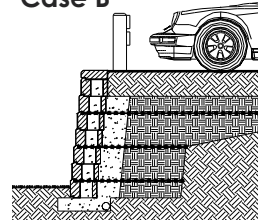

Case C

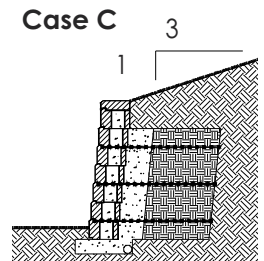

Geogrid sections shown, no-fines concrete similar

Design Parameters

Factors of Safety

Sliding	= 1.5
Overturning	= 2.0
No-Fines Overturning	= 1.5
Grid Pullout	= 1.5
Grid Rupture	= 1.5

Assumed Unit Weights

Earth Backfill	= 120 lbs/ft ³ (19 kN/m ³)
Filled weight of AB	= 131 lbs/ft ³ (20.5 kN/m ³)
Allan Block	= 135 lbs/ft ³ (21.1 kN/m ³)
No-Fines Concrete	= 110 lbs/ft ³ (17.3 kN/m ³)

General

Proper drainage provided.
Grid meets ASTM D-4595.

Assumed Soil Capacities

Cohesion	= 0 psf (0 kPa)
Bearing Capacity 36° (Ref)	≥ 4,000 psf (191.520 kPa)
Bearing Capacity 32° (Ref)	≥ 3,500 psf (167.580 kPa)
Bearing Capacity 27° (Ref)	≥ 2,500 psf (119.700 kPa)

Grid

Long Term Allowable Design Strength (LTADS) ≥ 700 lbs/ft. (10,200 N/m)

These charts should be used for **estimating** grid and no-fines concrete quantities for projects which match the site and soil descriptions provided, and only for projects which use grid strengths of 700 lbs/ft. (10,200 N/m) or higher. **No provision or analysis for global stability or seismic activity are provided.**

Table 6.2

No-Fines Chart				Soil Types: Coarse to medium sands, clean sand and gravel, little or no-fines - $\phi = 36^\circ$				Soil Types: Uniform to well graded sands, silty sands - $\phi = 32^\circ$				Soil Types: Sand-Silt-Clay mix, Clayey sands - $\phi = 27^\circ$				
				Depth of No-Fines including wall facing												
Condition Above Wall	Wall Height		Buried Block		12° (Ref) AB Stones only of the AB Collection		6° or 3° (Ref) AB, AB Europa and AB Fieldstone Collections (Excl. AB Stones)		12° (Ref) AB Stones only of the AB Collection		6° or 3° (Ref) AB, AB Europa and AB Fieldstone Collections (Excl. AB Stones)		12° (Ref) AB Stones only of the AB Collection		6° or 3° (Ref) AB, AB Europa and AB Fieldstone Collections (Excl. AB Stones)	
					ft	m	ft	m	ft	m	ft	m	ft	m	ft	m
Case A Level Slope Above the Wall	3	0.9	3	8	-	-	-	-	-	-	-	-	-	-	-	-
	4	1.2	4	10	-	-	-	-	-	-	-	-	2	0.7	2	0.7
	5	1.5	5	13	-	-	2	0.7	-	-	2	0.7	2	0.7	2.5	0.8
	6	1.8	6	15	2	0.7	2.5	0.8	2	0.7	2.5	0.8	2.5	0.8	2.5	0.8
	7	2.1	7	18	2.5	0.8	2.5	0.8	2.5	0.8	2.5	0.8	2.5	0.8	3	1
	8	2.4	8	20	2.5	0.8	3	1	2.5	0.8	3.5	1.1	3.5	1.1	3.5	1.1
	9	2.7	9	23	3	1	3.5	1.1	3	1	3.5	1.1	3.5	1.1	4	1.3
10	3.0	10	25	3.5	1.1	4	1.3	3.5	1.1	4	1.3	4	1.3	4.5	1.4	
Case B 100 psf Surcharge* (4.7 kPa) Above the Wall Top grid layer must extend an extra 3 ft (0.9 m)	3	0.9	3	8	-	-	2	0.7	-	-	2	0.7	2	0.7	2.5	0.8
	4	1.2	4	10	-	-	2	0.7	2	0.7	2	0.7	2	0.7	3	1
	5	1.5	5	15	2	0.7	2.5	0.8	2	0.7	2.5	0.8	2.5	0.8	3.5	1.1
	6	1.8	6	15	2	0.7	2.5	0.8	2	0.7	2.5	0.8	3	1	3.5	1.1
	7	2.1	7	18	2.5	0.8	3	1	2.5	0.8	3	1	3.5	1.1	4	1.3
	8	2.4	8	20	2.5	0.8	3	1	2.5	0.8	3.5	1.1	4	1.3	4.5	1.4
	9	2.7	9	23	3	1	3.5	1.1	3	1	4	1.3	4.5	1.4	5	1.6
10	3.0	10	25	3.5	1.1	4	1.3	3.5	1.1	4	1.3	4.5	1.4	5	1.6	
Case C 3H:1V Slope Above the Wall	3	0.9	3	8	-	-	-	-	-	-	-	-	2	0.7	2.5	0.8
	4	1.2	4	10	-	-	2	0.7	-	-	2	0.7	2.5	0.8	3	1
	5	1.5	5	13	-	-	2	0.7	2	0.7	2.5	0.8	3.4	1.1	4	1.3
	6	1.8	6	15	2	0.7	2.5	0.8	2	0.7	3	1	4	1.3	5	1.6
	7	2.1	7	18	2.5	0.8	3	1	2.5	0.8	3	1	4.5	1.4	5.5	1.7
	8	2.4	8	20	2.5	0.8	3	1	2.5	0.8	3.5	1.1	5	1.6	6.5	2
	9	2.7	9	23	3	1	3.5	1.1	3	1	4	1.3	5.5	1.7	7	2.2
10	3.0	10	25	3.5	1.1	4	1.3	3.5	1.1	4.5	1.4	6.5	2	8	2.5	



The charts below assume for geogrid reinforced walls, that the reinforcement starts on the first course of block, and then every second course thereafter. The charts below are for material estimates only, contact your local engineer for wall design.

Table 6.3

Geogrid Chart AB Stones - 12°					<i>Soil Types: Coarse to medium sands, clean sand and gravel, little or no-fines - $\phi = 36^\circ$</i>			<i>Soil Types: Uniform to well graded sands, silty sands - $\phi = 32^\circ$</i>			<i>Soil Types: Sand-Silt-Clay mix, Clayey sands - $\phi = 27^\circ$</i>		
Condition Above Wall	Wall Height		Buried Block		# of grid layers	Grid Lengths		# of grid layers	Grid Lengths		# of grid layers	Grid Lengths	
	ft	m	in	cm		ft	m		ft	m		ft	m
Case A Level Slope Above the Wall	3	0.9	3	8	0	-	-	0	-	-	0	-	-
	4	1.2	4	10	0	-	-	0	-	-	3	3	1
	5	1.5	5	13	0	-	-	0	-	-	4	3.5	1.1
	6	1.8	6	15	5	4	1.3	5	4	1.3	5	4	1.3
	7	2.1	7	18	6	5	1.6	6	5	1.6	6	5	1.6
	8	2.4	8	20	7	5.5	1.7	7	5.5	1.7	7	5.5	1.7
	9	2.7	9	23	7	6	1.9	7	6	1.9	7	6	1.9
10	3.0	10	25	8	6.5	2	8	6.5	2	8	6.5	2	
Case B 100psf Surcharge* (4.7 kPa) Above the Wall Top grid layer must extend an extra 3 ft (0.9 m)	3	0.9	3	8	0	-	-	0	-	-	2	3	1
	4	1.2	4	10	0	-	-	0	-	-	3	3	1
	5	1.5	6	15	4	3.5	1.1	4	3.5	1.1	4	3.5	1.1
	6	1.8	6	15	5	4	1.3	5	4	1.3	5	4	1.3
	7	2.1	7	18	6	5	1.6	6	5	1.6	6	5	1.6
	8	2.4	8	20	7	5.5	1.7	7	5.5	1.7	7	5.5	1.7
	9	2.7	9	23	7	6	1.9	7	6	1.9	7	6	1.9
10	3.0	10	25	8	6.5	2	8	6.5	2	8	6.5	2	
Case C 3H:1V Slope Above the Wall	3	0.9	3	8	0	-	-	0	-	-	2	3	1
	4	1.2	4	10	0	-	-	0	-	-	3	3	1
	5	1.5	5	13	0	-	-	0	-	-	4	3.5	1.1
	6	1.8	6	15	5	4	1.3	5	4	1.3	5	4	1.3
	7	2.1	7	18	6	5	1.6	6	5	1.6	6	5	1.6
	8	2.4	8	20	7	5.5	1.7	7	5.5	1.7	7	5.5	1.7
	9	2.7	9	23	7	6	1.9	7	6	1.9	7	6	1.9
10	3.0	10	25	8	6.5	2	8	6.5	2	9**	6.5	2	

Geogrid Chart AB Classic - 6°, Patterned Walls - 6°, AB Fieldstone - 6° & AB Vertical - 3°					<i>Soil Types: Coarse to medium sands, clean sand and gravel, little or no-fines - $\phi = 36^\circ$</i>			<i>Soil Types: Uniform to well graded sands, silty sands - $\phi = 32^\circ$</i>			<i>Soil Types: Sand-Silt-Clay mix, Clayey sands - $\phi = 27^\circ$</i>		
Condition Above Wall	Wall Height		Buried Block		# of grid layers	Grid Lengths		# of grid layers	Grid Lengths		# of grid layers	Grid Lengths	
	ft	m	in	cm		ft	m		ft	m		ft	m
Case A Level Slope Above the Wall	3	0.9	3	8	0	-	-	0	-	-	2	3	1
	4	1.2	6	15	3	3.5	1.1	3	3.5	1.1	3	3.5	1.1
	5	1.5	6	15	4	4	1.3	4	4	1.3	4	4	1.3
	6	1.8	6	15	5	5	1.6	5	5	1.6	5	5	1.6
	7	2.1	7	18	6	5.5	1.7	6	5.5	1.7	6	5.5	1.7
	8	2.4	8	20	7	6.5	2	7	6.5	2	7	6.5	2
	9	2.7	9	23	7	7	2.2	7	7	2.2	7	7	2.2
10	3.0	10	25	8	7.5	2.3	8	7.5	2.3	8	7.5	2.3	
Case B 100psf Surcharge* (4.7 kPa) Above the Wall Top grid layer must extend an extra 3 ft (0.9 m)	3	0.9	6	15	2	3	1	2	3	1	2	3	1
	4	1.2	6	15	3	3.5	1.1	3	3.5	1.1	3	3.5	1.1
	5	1.5	6	15	4	4	1.3	4	4	1.3	4	4	1.3
	6	1.8	6	15	5	5	1.6	5	5	1.6	5	5	1.6
	7	2.1	7	18	6	5.5	1.7	6	5.5	1.7	6	5.5	1.7
	8	2.4	8	20	7	6.5	2	7	6.5	2	7	6.5	2
	9	2.7	9	23	7	7	2.2	7	7	2.2	7	7	2.2
10	3.0	10	25	8	7.5	2.3	8	7.5	2.3	9**	7.5	2.3	
Case C 3H:1V Slope Above the Wall	3	0.9	3	8	0	-	-	0	-	-	2	3	1
	4	1.2	6	15	3	3.5	1.1	3	3.5	1.1	3	3.5	1.1
	5	1.5	6	15	4	4	1.3	4	4	1.3	4	4	1.3
	6	1.8	6	15	5	5	1.6	5	5	1.6	5	5	1.6
	7	2.1	7	18	6	5.5	1.7	6	5.5	1.7	6	5.5	1.7
	8	2.4	8	20	7	6.5	2	7	6.5	2	8**	6.5	2
	9	2.7	9	23	7	7	2.2	7	7	2.2	8**	7.5	2.3
10	3.0	10	25	8	7.5	2.3	9**	7.5	2.3	10***	8.5	2.6	

Note: All walls which require geogrid reinforcement shall have a minimum of 6 in. (150 mm) of buried block.

Tables 6.2 and 6.3 are based on Clay soil having an internal friction angle of 27° (Ref) or better and a Sandy soil having an internal friction angle of 32° (Ref) or better and a Sand/Gravel soils having an internal friction angle of 36° (Ref) or better. All setbacks and dimensions are approximate. The wall heights shown do not account for seismic loading. Check with a local engineer for assistance if you are in a seismic area. Final designs for construction purposes must be performed by a local registered Professional Engineer, using the actual conditions of the proposed site.

*The Surcharge loading category above assumes a solid surface such as concrete, asphalt or pavers having a suitable supporting subgrade.

** 1 course spacing for first 3 layers of grid. *** 1 course spacing for first 4 layers of grid.

Specification Guidelines: Allan Block Modular Retaining Wall Systems

SECTION 1

PART 1: GENERAL

1.1 Scope

Work includes furnishing and installing modular concrete block retaining wall units to the lines and grades designated on the construction drawings and as specified herein.

1.2 Applicable Sections of Related Work

Geogrid Wall Reinforcement (See Section 2)

1.3 Reference Standards

- A. ASTM C1372 Standard Specification for Segmental Retaining Wall Units.
- B. ASTM 1262 Evaluating the Freeze Thaw Durability of Manufactured CMU's and Related Concrete Units
- C. ASTM D698 Moisture Density Relationship for Soils, Standard Method
- D. ASTM D422 Gradation of Soils
- E. ASTM C140 Sample and Testing Concrete Masonry Units

1.4 Delivery, Storage, and Handling

- A. Contractor shall check the materials upon delivery to assure proper material has been received.
- B. Contractor shall prevent excessive mud, cementitious material, and like construction debris from coming in contact with the materials.
- C. Contractor shall protect the materials from damage. Damaged material shall not be incorporated in the project (ASTM C1372).

PART 2: MATERIALS

2.1 Modular Wall Units

- A. Wall units shall be Allan Block Retaining Wall units as produced by a licensed manufacturer.
- B. Wall units shall have minimum 28 day compressive strength of 3000 psi (20.7 MPa) in accordance with ASTM C1372. The concrete units shall have adequate freeze-thaw protection in accordance with ASTM C1372 or an average absorption rate of 7.5 lb/ft³ (120 kg/m³) for northern climates and 10 lb/ft³ (160 kg/m³) for southern climates.
- C. Exterior dimensions shall be uniform and consistent. Maximum dimensional deviations on the height of any two units shall be 0.125 in. (3 mm).
- D. Wall units shall provide a minimum of 110 lbs total weight per square foot of wall face area (555 kg/m²). Fill contained within the units may be considered 80% effective weight.
- E. Exterior face shall be textured. Color as specified by owner.
- F. Freeze Thaw Durability: Like all concrete products, dry-cast concrete SRW units are susceptible to freeze-thaw degradation with exposure to de-icing salts and cold temperature. This is a concern in northern tier states or countries that use de-icing salts. Based on good performance experience by several agencies, ASTM C1372, or equivalent governing standard or public authority, Standard Specification for Segmental Retaining Wall Units should be used as a model, except that, to increase durability, the compressive strength for the units should be increased to a minimum of 4,000 psi (28 MPa) unless local requirements dictate higher levels.

Also, maximum water absorption should be reduced and requirements for freeze-thaw testing increased.

- a. Require a current passing ASTM C 1262 or equivalent governing standard or public authority, test report from material supplier in northern or cold weather climates .
- b. Where de-icing chemicals land on a SRW retaining wall, consider a more durable capping unit. Durability concerns occur where there are saturated conditions in repeated freezing and thawing conditions.
- c. In areas where SRW's are exposed to repeated exposure from snow removal equipment, consider sealants or water repelling chemicals periodically applied to the walls (silane and siloxane compounds).

Freeze Thaw Durability Criterion (From the NCMA)		
Exposure Conditions	Minimum Compressive Strength	Minimum Freeze-Thaw Durability Criteria
Negligible	Per Design Specs	No freeze-thaw testing required
Moderate	28 MPa (4000 psi)	Where block units will NOT be exposed to De-Icing Salts: Less than 1% weight loss after 100 cycles for 5 of 5 specimens OR less than 1.5% weight loss after 150 cycles for 4 of 5 specimens. Tested using ASTM C1262 in tap water.
Moderate/ Severe	40 MPa (5800 psi)	Where block units will be exposed to De-Icing Salts: Less than 1% weight loss after 40 cycles for 5 of 5 specimens OR less than 1.5% weight loss after 50 cycles for 4 of 5 specimens. Tested using ASTM C1262 in 3% saline solution

In northern climates that are considered to be more arid, the environment that creates freeze-thaw durability issues may not be present. The local engineer of record needs to evaluate if continued wetting of the facing units creates an environment where durability concerns are warranted.



G. Freeze Thaw Testing Criteria: The need for higher levels of Freeze Thaw durability is primarily a regional requirement. In lieu of written criterion from a local governing body or public authority, the Freeze Thaw Durability Criterion provides testing criterion for areas considered negligible, moderate or severe:

Exposure	Average Winter Low Temperature
Negligible	> 32 deg F (0 degrees C)
Moderate	< 32 deg and >20 deg F (0 and -7 C)
Severe	< 20 deg F (-7 deg C)

Sieve Size	Percent Passing
1 in (25 mm)	100 - 75
No. 4	100 - 20
No. 40	0 - 60
No. 200	0 - 35

2.2 Wall Rock

- A. Material must be well-graded compactible aggregate, 0.25 in. to 1.5 in., (6 mm-38 mm) with no more than 10% passing the #200 sieve. (ASTM D422)
- B. Material behind and within the blocks may be the same material.

2.3 Infill Soil

- A. Infill material shall be site excavated soils when approved by the on-site soils engineer unless otherwise specified in the drawings. Unsuitable soils for backfill (heavy clays or organic soils) shall not be used in the reinforced soil mass. Fine grained cohesive soils [$\phi < 31^\circ$ (Ref)] may be used in wall construction, but additional backfilling, compaction and water management efforts are required. Poorly graded sands, expansive clays and/or soils with a plasticity index (PI) >20 or a liquid limit (LL) >40 should not be used in wall construction.
- B. The infill soil used must meet or exceed the designed friction angle and description noted on the design cross sections, and must be free of debris and consist of one of the following inorganic USCS soil types: GP, GW, SW, SP meeting the following gradation as determined in accordance with ASTM D422.
- C. Where additional fill is required, contractor shall submit sample and specifications to the wall design engineer or the on-site soils engineer for approval and the approving engineer must certify that the soils proposed for use has properties meeting or exceeding original design standards.

PART 3: WALL CONSTRUCTION

3.1 Contractor Requirements

Contractors shall be trained and certified by local manufacturer or equivalent accredited organization.

- A. Allan Block and NCMA have certification programs that are accredited. Identify when advanced certification levels are appropriate based on complexity and criticality of project application.
- B. Contractors shall provide a list of projects they have completed.

3.2 Excavation

- A. Contractor shall excavate to the lines and grades shown on the construction drawings. Contractor shall use caution not to over-excavate beyond the lines shown, or to disturb the base elevations beyond those shown.
- B. Contractor shall verify locations of existing structures and utilities prior to excavation. Contractor shall ensure all surrounding structures are protected from the effects of wall excavation.

3.3 Foundation Soil Preparation

- A. Foundation soil shall be defined as any soils located beneath a wall.
- B. Foundation soil shall be excavated as dimensioned on the plans and compacted to a minimum of 95% of Standard Proctor (ASTM D698) prior to placement of the base material.
- C. Foundation soil shall be examined by the on-site soils engineer to ensure that the actual foundation soil strength meets or exceeds assumed design strength. Soil not meeting the required strength shall be removed and replaced with acceptable material.

3.4 Base

- A. The base material shall be the same as the Wall Rock material (Section 2.2) or a low permeable granular material.
- B. Base material shall be placed as shown on the construction drawing. Top of base shall be located to allow bottom wall units to be buried to proper depths as per wall heights and specifications.
- C. Base material shall be installed on undisturbed native soils or suitable replacement fills compacted to a minimum of 95% Standard Proctor (ASTM D698).
- D. Base shall be compacted at 95% Standard Proctor (ASTM D698) to provide a level hard surface on which to place the first course of blocks. The base shall be constructed to ensure proper wall embedment and the final elevation shown on the plans. Well-graded sand can be used to smooth the top 1/2 in. (13 mm) on the base material.
- E. Base material shall be a 4 in. (100 mm) minimum depth for walls under 4 ft (1.2 m) and a 6 in. (150 mm) minimum depth for walls over 4 ft (1.2 m).

3.5 Unit Installation

- A. The first course of wall units shall be placed on the prepared base per the manufacturers installation recommendations. The units shall be checked for level and alignment as they are placed.

- B. Ensure that units are in full contact with base. Proper care shall be taken to develop straight lines and smooth curves on base course as per wall layout.
- C. Fill all cores and cavities and a minimum of 12 in. (300 mm) behind the base course with wall rock. Use infill soils behind the wall rock and approved soils in front of the base course to firmly lock in place. Check again for level and alignment. Use a plate compactor to consolidate the area behind the base course. All excess material shall be swept from top of units.
- D. Install next course of wall units on top of base row. Position blocks to be offset from seams of blocks below. Perfect "running bond" is not essential, but a 3 in. (75 mm) minimum offset is recommended. Check each block for proper alignment and level. Fill all cavities in and around wall units and to a minimum of 12 in. (300 mm) depth behind block with wall rock. For taller wall application the depth of wall rock behind the block should be increased; walls from 15 ft (4.6 m) to 25 ft (7.6 m) should have a minimum of 2 ft (0.6 m) and walls above 25 ft (7.6 m) should have a minimum of 3 ft (0.9 m). Spread infill soil in uniform lifts not exceeding 8 in. (200 mm) in uncompacted thickness and compact to 95% of Standard Proctor (ASTM D698) behind the consolidation zone.
- E. The consolidation zone shall be defined as 3 ft (0.9 m) behind the wall. Compaction within the consolidation zone shall be accomplished by using a hand operated plate compactor and shall begin by running the plate compactor directly on the block and then compacting in parallel paths from the wall face until the entire consolidation zone has been compacted. A minimum of two passes of the plate compactor are required with maximum lifts of 8 in. (200 mm). Expansive or fine-grained soils may require additional compaction passes and/or specific compaction equipment such as a sheepsfoot roller. Maximum lifts of 4 inches (100 mm) may be required to achieve adequate compaction within the consolidation zone. Employ methods using lightweight compaction equipment that will not disrupt the stability or batter of the wall. Final compaction requirements in the consolidation zone shall be established by the engineer of record.
- F. Install each subsequent course in like manner. Repeat procedure to the extent of wall height.
- G. As with any construction work, some deviation from construction drawing alignments will occur. Variability in construction of SRWs is approximately equal to that of cast-in-place concrete retaining walls. As opposed to cast-in-place concrete walls, alignment of SRWs can be simply corrected or modified during construction. Based upon examination of numerous completed SRWs, the following recommended minimum tolerances can be achieved with good construction techniques.

Vertical Control - ± 1.25 in. (32 mm) max. over 10 ft (3 m) distance.

Horizontal Location Control - straight lines ± 1.25 in. (32 mm) over a 10 ft (3 m) distance.

Rotation - from established plan wall batter : 2.0°

Bulging - 1.0 in. (25 mm) over a 10 ft (3.0 m) distance

3.6 Additional Construction Notes

- A. When one wall branches into two terraced walls, it is important to note that the soil behind the lower wall is also the foundation soil beneath the upper wall. This soil shall be compacted to a minimum of 95% of Standard Proctor (ASTM D698) prior to placement of the base material. Achieving proper compaction in the soil beneath an upper terrace prevents settlement and deformation of the upper wall. One way is to replace the soil with wall rock and compact in 8 in. (200 mm) lifts. When using on-site soils, compact in maximum lifts of 4 in. (100 mm) or as required to achieve specified compaction.
- B. Filter fabric use is not suggested for use with cohesive soils. Clogging of such fabric creates unacceptable hydrostatic pressures in soil reinforced structures. When filtration is deemed necessary in cohesive soils, use a three dimensional filtration system of clean sand or filtration aggregate.
- C. Embankment protection fabric is used to stabilize rip rap and foundation soils in water applications and to separate infill materials from the retained soils. This fabric should permit the passage of fines to preclude clogging of the material. Embankment protection fabric shall be a high strength polypropylene monofilament material designed to meet or exceed typical Corps of Engineers plastic filter fabric specifications (CW-02215); stabilized against ultraviolet (UV) degradation and typically exceeding the values on Table 1. **(see the Water Management section of AB Spec Book).**
- D. Water management is of extreme concern during and after construction. Steps must be taken to ensure that drain pipes are properly installed and vented to daylight and a grading plan has been developed that routes water away from the retaining wall location. Site water management is required both during construction of the wall and after completion of construction.

Consult the Allan Block Engineering Department for details 800-899-5309.

A specification subject to change without notice, this document was last updated on 11/20/2014.

Geogrid Reinforcement Systems



allanblock.com

SECTION 2

PART 1: GENERAL

1.1 Scope

Work includes furnishings and installing geogrid reinforcement, wall block, and backfill to the lines and grades designated on the construction drawings and as specified herein.

1.2 Applicable Section of Related Work

Section 1: Allan Block Modular Retaining Wall Systems. (See Section 1)

1.3 Reference Standards

See specific geogrid manufacturers reference standards.

Additional Standards:

- A. ASTM D4595 - Tensile Properties of Geotextiles by the Wide-Width Strip Method
- B. ASTM D5262 - Test Method for Evaluating the Unconfined Creep Behavior of Geogrids
- C. ASTM D6638 Grid Connection Strength (SRW-U1)
- D. ASTM D6916 SRW Block Shear Strength (SRW-U2)
- E. GRI-GG4 - Grid Long Term Allowable Design Strength (LTADS)
- F. ASTM D6706 - Test Method for Geogrid Pullout

1.4 Delivery, Storage, and Handling

- A. Contractor shall check the geogrid upon delivery to assure that the proper material has been received.
- B. Geogrid shall be stored above -10° F (-23° C).
- C. Contractor shall prevent excessive mud, cementitious materials, or other foreign materials from coming in contact with the geogrid material.

PART 2: MATERIALS

2.1 Definitions

- A. Geogrid products shall be of high density polyethylene or polyester yarns encapsulated in a protective coating specifically fabricated for use as a soil reinforcement material.
- B. Concrete retaining wall units are as detailed on the drawings and shall be Allan Block Retaining Wall Units.
- C. Drainage material is free draining granular material as defined in Section 1, 2.2 Wall Rock.
- D. Infill soil is the soil used as fill for the reinforced soil mass.
- E. Foundation soil is the in-situ soil.

2.2 Products

Geogrid shall be the type as shown on the drawings having the property requirements as described within the manufacturers specifications.

2.3 Acceptable Manufacturers

A manufacturer's product shall be approved by the wall design engineer.

PART 3: WALL CONSTRUCTION

3.1 Foundation Soil Preparation

- A. Foundation soil shall be excavated to the lines and grades as shown on the construction drawings, or as directed by the on-site soils engineer.
- B. Foundation soil shall be examined by the on-site soils engineer to assure that the actual foundation soil strength meets or exceeds assumed design strength.
- C. Over-excavated areas shall be filled with compacted backfill material approved by on-site soils engineer.
- D. Contractor shall verify locations of existing structures and utilities prior to excavation. Contractor shall ensure all surrounding structures are protected from the effects of wall excavation.

3.2 Wall Construction

Wall construction shall be as specified under Section 1, Part 3, Wall Construction.

3.3 Geogrid Installation

- A. Install Allan Block wall to designated height of first geogrid layer. Backfill and compact the wall rock and infill soil in layers not to exceed 8 in. (200 mm) lifts behind wall to depth equal to designed grid length before grid is installed.
- B. Cut geogrid to designed embedment length and place on top of Allan Block to back edge of lip, for AB and AB Europa Collections, or the middle of the facing unit for the AB Fieldstone Collection. Extend away from wall approximately 3% above horizontal on compacted backfill.

- C. Lay geogrid at the proper elevation and orientations shown on the construction drawings or as directed by the wall design engineer.
- D. Correct orientation of the geogrid shall be verified by the contractor and on-site soils engineer. Strength direction is typically perpendicular to wall face.
- E. Follow manufacturers guidelines for overlap requirements. In curves and corners, layout shall be as specified in Design Details 9-12, **In the AB Spec Book.**
- F. Place next course of Allan Block on top of grid and fill block cores with wall rock to lock in place. Remove slack and folds in grid and stake to hold in place.
- G. Adjacent sheets of geogrid shall be butted against each other at the wall face to achieve 100 percent coverage.
- H. Geogrid lengths shall be continuous. Splicing parallel to the wall face is not allowed.

3.4 Fill Placement

- A. Infill soil shall be placed in lifts and compacted as specified under **Section 1, Part 3, Unit Installation.**
- B. Infill shall be placed, spread and compacted in such a manner that minimizes the development of slack or movement of the geogrid.
- C. Only hand-operated compaction equipment shall be allowed within 3 ft (0.9 m) behind the wall. This area shall be defined as the consolidation zone. Compaction in this zone shall begin by running the plate compactor directly on the block and then compacting in parallel paths from the wall face back, until the entire consolidation zone has been compacted. A minimum of two passes of the plate compactor are required with maximum lifts of 8 in. (200 mm). **Section 1, Part 3, Unit Installation.**
- D. When fill is placed and compaction cannot be defined in terms of Standard Proctor Density, then compaction shall be performed using ordinary compaction process and compacted so that no deformation is observed from the compaction equipment or to the satisfaction of the engineer of record or the site soils engineer.
- E. Tracked construction equipment shall not be operated directly on the geogrid. A minimum fill thickness of 6 in. (150 mm) is required prior to operation of tracked vehicles over the geogrid. Turning of tracked vehicles should be kept to a minimum to prevent tracks from displacing the fill and damaging the geogrid.
- F. Rubber-tired equipment may pass over the geogrid reinforcement at slow speeds, less than 10 mph (16 Km/h). Sudden braking and sharp turning shall be avoided.
- G. The infill soil shall be compacted to achieve 95% Standard Proctor (ASTM D698). Soil tests of the infill soil shall be submitted to the on-site soils engineer for review and approval prior to the placement of any material. The contractor is responsible for achieving the specified compaction requirements. The on-site soils engineer may direct the contractor to remove, correct or amend any soil found not in compliance with these written specifications.
- H. An independent testing firm should be hired by the owner to provide services.
- I. Independent firm to keep inspection log and provide written reports at predetermined intervals to the owner.
- J. Testing frequency should be set to establish a proper compaction protocol to consistently achieve the minimum compaction requirements set by the design requirements. If full time inspection and testing at 8 inch (20 cm) lifts is not provided, then the following testing frequency should be followed:
 - a. One test for every 8 inches (20 cm) of vertical fill placed and compacted, for every 25 lineal feet (7.6 m) of retaining wall length, starting on the first course of block.
 - b. Vary compaction test locations to cover the entire area of reinforced zone; including the area compacted by the hand-operated compaction equipment.
 - c. Once protocol is deemed acceptable, testing can be conducted randomly at locations and frequencies determined by the on-site soils engineer.
- K. Slopes above the wall must be compacted and checked in a similar manner.



3.5 Special Considerations

- A. Geogrid can be interrupted by periodic penetration of a column, pier or footing structure.
- B. Allan Block walls will accept vertical and horizontal reinforcing with rebar and grout.
- C. If site conditions will not allow geogrid embedment length, consider the following alternatives:
 - Masonry Reinforced Walls
 - Double Allan Block Wall
 - Earth Anchors
 - Rock Bolts
 - No-Fines Concrete
 - Soil Nailing
 - Increased Wall Batter

See the AB Spec Book, Design Details.

- D. Allan Block can be used in a wide variety of water applications.

See the AB Spec Book, Section 3, Part 1.8.

Consult the Allan Block Engineering Department for details 800-899-5309.

A specification subject to change without notice, this document was last updated on 08/4/2014.

TECHNICAL SUPPORT

For engineering and technical assistance on projects that fall beyond the scope of these guidelines, contact **ALLAN BLOCK CORPORATION** at **800-899-5309**.

Reference Guide

1) R0904-1114	Allan Block Engineering Manual, November 2014
2) R0901-0812	Allan Block Spec Book, August 2012
3) R0903-1107	Allan Block Seismic Testing Executive Summary, November 2007
4) R0615-1214	Best Practices for SRW Design, December 2014
5) IAPMO #ER-0198	Allan Block Evaluation Report, Published August 2011
6) ASTM C90	Load Bearing Concrete Masonry Units
7) ASTM C140	Sampling and Testing, Concrete Masonry Units
8) UBC 21	Hollow and Solid Load Bearing Concrete Masonry Units
9) ASTM C1372	Standard Specification for Segmental Retaining Wall Units
10) ASTM C1262	Evaluating Freeze Thaw Durability
11) ACI 318	Building Code Requirements for Reinforced Concrete
12) ASTM D6916	Standard Test Method for Determining the Shear Strength between Segmental Concrete Units
13) ASTM D6638	Standard Test Method for Determining Connection Strength between Geosynthetic Reinforcement and Segmental Concrete Units
14) FHWA-NHI-02-011	Mechanically Stabilized Earth Walls and Reinforced Soil Slopes
15) Jones, Colin JFP, <u>Earth Reinforcement and Soil Structures</u> , Butterworths, London, England (1985)	
16) Mitchell, J K, et. al. <u>Reinforcement of Earth Slopes and Embankments</u> , NCHRP Report 290, Transportation Research Board, Washington, DC (1987)	
17) Task Force 27, <u>In-Situ Soil Improvement Techniques</u> , "Design Guidelines for Use of Extensible Reinforcements for Mechanically Stabilized Earth Walls in Permanent Applications," Joint Committee of AASHTO-AGC-ARTBA, AASHTO, Washington, DC (1990)	
18) Terzaghi, K, and Peck, R B, <u>Soil Mechanics in Engineering Practice</u> , John Wiley and Sons, Inc., New York, NY (1967)	
19) GRI Standard Practice, GG4 : Determination of Long-Term Design Strength of Geogrids, Geosynthetic Research Institute, Drexel University, Philadelphia, PA (1991)	
20) Hoe I. Ling, et. al. <u>Large-Scale Shaking Table Tests on Modular-Block Reinforced Soil Retaining Walls</u> , Tsukuba, Japan (2005)	



Engineered for Performance

Allan Block provides the engineering flexibility to meet the most challenging design requirements including water and shoreline sites. Allan Block is fully engineered and tested and is the only retaining wall system to pass full seismic testing.

When proven performance is important, choose Allan Block.



allanblock.com





Site Solutions

Allan Block's extensive engineering provides the capability to meet a broad variety of applications. From sound barriers to industrial applications the Allan Block product can meet your needs. Its cost effective, long term performance makes it the product of choice for DOT projects across the country. It can be designed to accommodate the toughest federal, state and provincial specifications including applicable AASHTO and Task Force 27 requirements.

Allan Block has conducted the only full-scale seismic research for segmental retaining walls. The flexible nature and performance of the AB System astounded the experts. You can feel secure in knowing your Allan Block solution can withstand the test of time.





allanblock.com



To find the most up-to-date information as well as the other Allan Block products available, visit allanblock.com.





Facing Series: Sierra
Color: Kasota Gold



Facing Series: Colonial
Color: Rustic Creek



Facing Series: Sierra
Color: Sandstone



allanblock.com

Looking Towards the Future

The next generation of Allan Block products is here; *AB Fieldstone - Green, Natural and Friendly*. The patented two-piece system enables us to push the envelope in aesthetics, sustainability, and product opportunity.

So look to the future with us as Allan Block continues to innovate. Expect to see more of AB Fieldstone and all it has to offer as the next great wall solution, from the company you have come to trust – Allan Block.

With the same plan, design and build process as the other Allan Block retaining wall systems, you can now have AB Fieldstone. The most innovative Green, Natural and Friendly product on the market.

AB Fieldstone Typical Reinforced Wall Cross Section

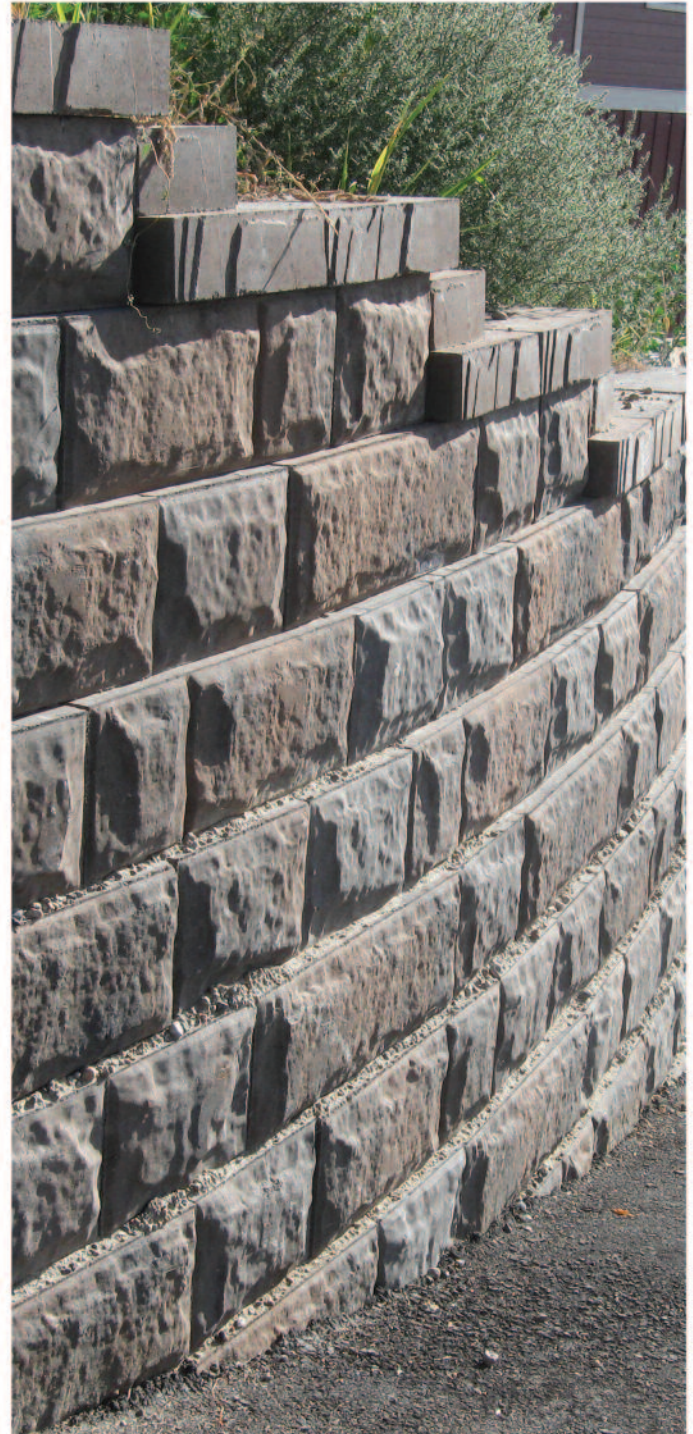
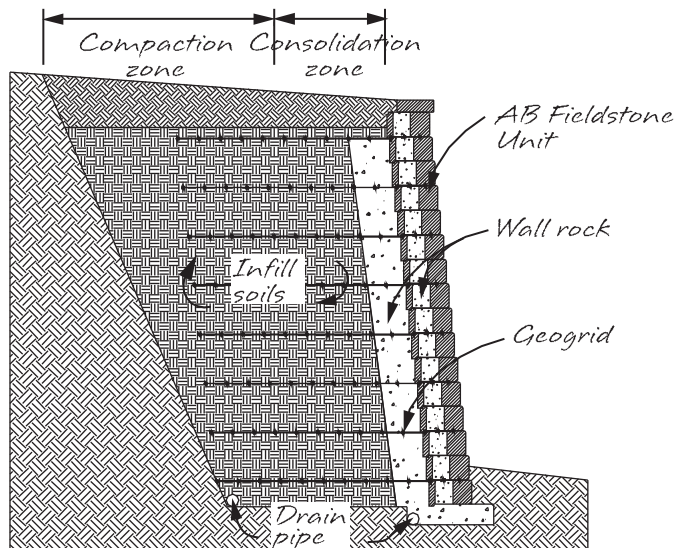

The information and product applications illustrated in this manual have been carefully compiled by the Allan Block Corporation and, to the best of our knowledge, accurately represent Allan Block product use. Final determination of the suitability of any information or material for the use contemplated and its manner of use is the sole responsibility of the user. Structural design analysis shall be performed by a qualified engineer.



allanblock.com



Printed on
Paper with 10%
Recycled Fiber