



# MASONRY BLOCKS

| 10, 15, 20 & 25 SERIES  
| BLOCK RANGES

VERSION 5 | [WWW.BOWERSBROTHERS.CO.NZ](http://WWW.BOWERSBROTHERS.CO.NZ)





# ABOUT BOWERS MASONRY

Bowers Brothers Concrete's long-standing presence in the industry and our commitment to sustainable practices is ingrained in our mission to ensure a positive future for the next generation. As a family-owned concrete manufacturing company's our history spans over 90 years, this showcases our company's dedication and expertise.

The expansion of branches throughout the Waikato and in Auckland shows a strong focus on providing concrete products to a wide customer base. Collaborations with key Building Supply Merchants across the North Island further highlight Bowers dedication to delivering quality products to our customers.

Our state-of-the-art Columbia block machines for manufacturing masonry blocks, bricks, paving, and retaining wall products showcases Bowers commitment to utilising advanced technology to produce a diverse range of high-quality concrete products.

The transition of the Bowers Morrinsville Masonry Plant to solar power since January 2022 is a remarkable step toward sustainability and reducing our company's carbon footprint. This move not only showcases our commitment to environmental responsibility but also positions Bowers Brothers Concrete as an eco-conscious leader in the industry.

## STANDARD MASONRY

Low maintenance is the key for choosing Bowers Blocks. Our blocks are made with high quality concrete to ensure our customers have years of trouble free living, while providing added strength, noise control, protection from fire and comfort to your build.

## ARCHITECTURAL FINISHES

We are able to assist with your architectural masonry needs. We can add to the aesthetic appeal of a standard block, either left in its natural state or by creating a range of coloured blocks or assist in achieving a Fair Face, Honed or Shot Blasted finish.





# 10 SERIES MASONRY BLOCK



Masonry Block 10 Series is a versatile and innovative option for architectural projects. Its slim profile and design versatility make it suitable for a range of applications, especially where aesthetics and practicality are both important factors. The fact that they can serve as a brick veneer alternative and help create distinctive feature walls highlights their potential for enhancing the visual appeal of a building.

One of the key advantages of the Masonry Block 10 Series is its slimness, which sets it apart from traditional masonry blocks. This slim profile opens up new possibilities for design flexibility and can even help save space in construction projects. This is particularly valuable in today's urban environments where efficient use of space is often a priority.

Additionally, the Masonry Block 10 Series' can provide an additional layer of protection. These blocks could potentially contribute to improved fire safety measures in buildings.

Masonry Block 10 Series offers a blend of aesthetic appeal, design flexibility, space-saving potential, and fire protection. Architects, designers, and builders might find these blocks to be a valuable asset for their projects, especially when seeking a balance between functional requirements and visual enhancements.

## STANDARD COLOUR



NATURAL

## MADE-TO-ORDER COLOUR\*

\*Made to order colours are available on a minimum order quantity. Please talk to your local Bowers representative for more information.



MIDNIGHT

**NOTE:** Colours shown may alter, due to the limitation of the colour printing process of this catalogue.

This product is not subject to a warning or ban under the Building Act 2004, or a description of any warning or ban that has been made in relation to the product.

## FINISHES\*

\*Made to order finishes are available on a minimum order quantity.



FAIR FACED

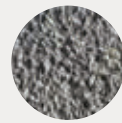

SHOTBLASTED

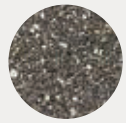

HONED





# 15 SERIES MASONRY BLOCK



15 Series Masonry Blocks have a strategic positioning within the product line-up, offering a balance between the larger and more visually expansive 20 and 25 Series blocks, and the smaller 10 Series versatile blocks.

These masonry blocks strike a balance between visual impact and versatility due to their middle-sized form. Their robust appearance contributes to architectural appeal, which can be a desirable feature in construction projects. Their smaller size gives them versatility, making them suitable for various construction applications. This adaptability could be especially useful when working on projects with different design requirements.

15 Series Masonry Blocks are designed to enhance the visual appeal of a building. This is achieved through their well-balanced size and robust appearance, which can contribute to an aesthetically pleasing overall look.

Bowers offer a range of finishing options, which can further enhance the masonry block visual appeal and adaptability. These options include leaving the blocks in their natural state, applying different colours, or achieving specific finishes like Fairface, Honed, or Shot Blasted. This variety allows builders and architects to customise the blocks' appearance to suit the design vision of a project.

## STANDARD COLOUR



NATURAL

## MADE-TO-ORDER COLOUR\*

\*Made to order colours are available on a minimum order quantity. Please talk to your local Bowers representative for more information.



MIDNIGHT

**NOTE:** Colours shown may alter, due to the limitation of the colour printing process of this catalogue.

This product is not subject to a warning or ban under the Building Act 2004, or a description of any warning or ban that has been made in relation to the product.

## FINISHES\*

\*Made to order finishes are available on a minimum order quantity.



FAIR FACED

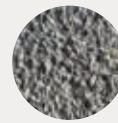

SHOTBLASTED

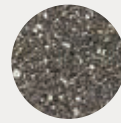

HONED





# 20 SERIES MASONRY BLOCK



20 Series Masonry Blocks versatility for various construction applications is a valuable attribute. This versatility likely stems from their design, size, and composition, which enable them to be used effectively in a wide range of building projects.

Specifically, the Bowers 20 Series Masonry Blocks are noted for being well-suited for constructing walls in different types of buildings. This is due to their structural integrity, ease of use and compatibility with various construction methods.

One beneficial highlight of using these blocks is their positive impact on the overall well-being of a building. The blocks offer more than just structural support; they actively contribute to the comfort and quality of the living or working environment.

Masonry blocks contribute to improved insulation within the building. This means better temperature regulation, which is important for energy efficiency and occupant comfort. Bowers masonry blocks aid in noise control. They have acoustic insulation properties, helping to reduce the transmission of external noise into the building. This is a significant feature for creating a quiet and peaceful indoor environment.

By reducing external noise and improving insulation, the Bowers 20 Series Masonry Blocks can contribute to a more comfortable living or working space. This aligns with the growing emphasis on creating buildings that prioritise occupant comfort and well-being.

## STANDARD COLOUR



NATURAL

## MADE-TO-ORDER COLOUR\*

\*Made to order colours are available on a minimum order quantity. Please talk to your local Bowers representative for more information.



MIDNIGHT

**NOTE:** Colours shown may alter, due to the limitation of the colour printing process of this catalogue.

This product is not subject to a warning or ban under the Building Act 2004, or a description of any warning or ban that has been made in relation to the product.

## FINISHES\*

\*Made to order finishes are available on a minimum order quantity.



FAIR FACED



SHOTBLASTED

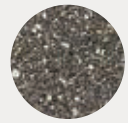

HONED





# 25 SERIES MASONRY BLOCK

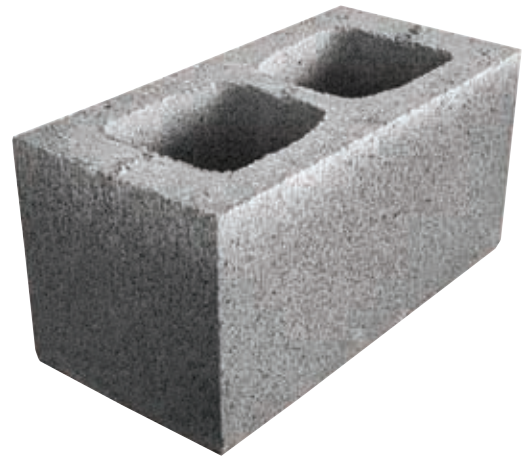

Masonry Block 25 Series primary selling point is the low maintenance aspect of the block. This feature resonates with customers looking for durable and hassle-free building materials that require minimal upkeep over the years.

The use of high-quality concrete in manufacturing the blocks is a crucial factor in ensuring their longevity and performance.

This reinforces the notion that customers can expect reliable and lasting results from these masonry blocks.

Durability and quality of Masonry Block 25 Series blocks leads to years of trouble-free living. These blocks contribute to the overall structural integrity of the building. This is appealing for projects where strength and stability are critical factors.

An important feature is masonry blocks are made from fire-resistant materials which is an attractive quality for customers who prioritise added protection in their construction projects.

Bowers offers a range of finishing options and assists with achieving specific finishes that is valuable for projects where a unique and personalised look is desired. The versatility in finishing options – natural state, coloured blocks, Fairface, Honed, or Shot Blasted finish – provides customers with a range of choices to match their design preferences.

## STANDARD COLOUR



NATURAL

## MADE-TO-ORDER COLOUR\*

\*Made to order colours are available on a minimum order quantity. Please talk to your local Bowers representative for more information.



MIDNIGHT

**NOTE:** Colours shown may alter, due to the limitation of the colour printing process of this catalogue.

This product is not subject to a warning or ban under the Building Act 2004, or a description of any warning or ban that has been made in relation to the product.

## FINISHES\*

\*Made to order finishes are available on a minimum order quantity.



FAIR FACED

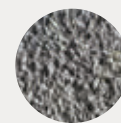

SHOTBLASTED

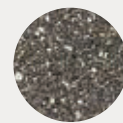

HONED

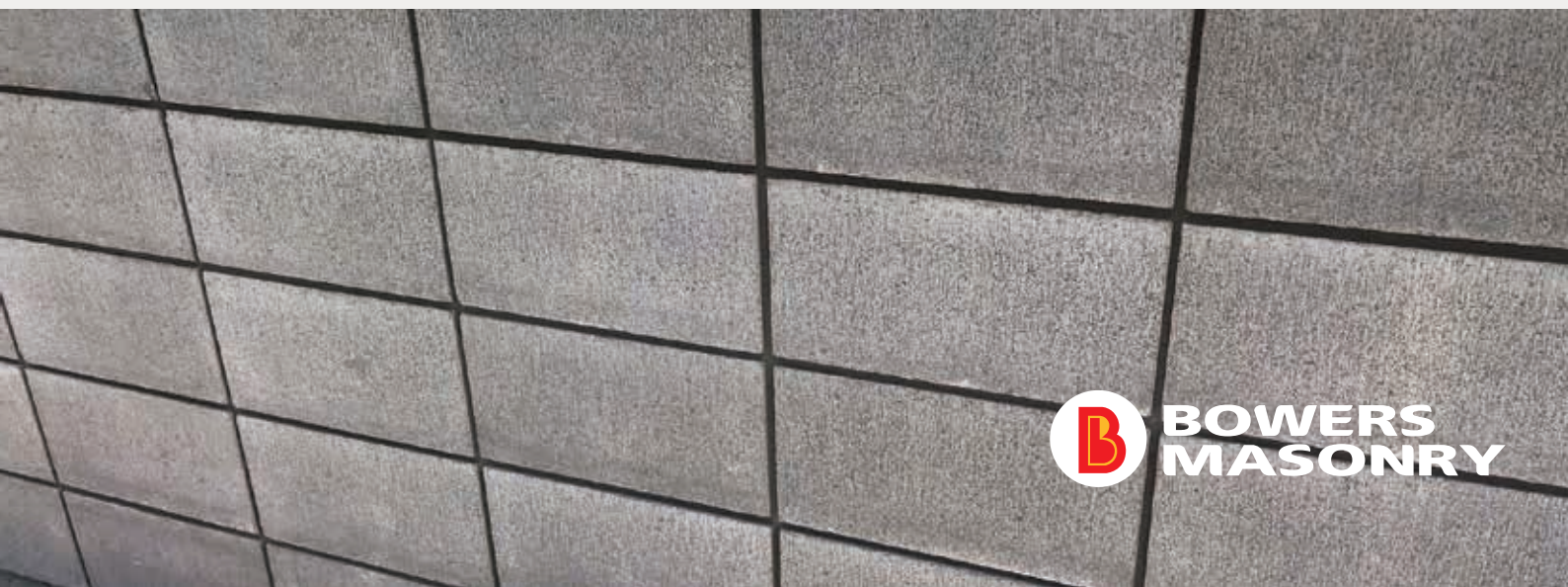

**BOWERS  
MASONRY**

# BOWERS MASONRY

## BLOCK RANGE

### 10 SERIES

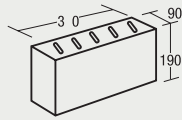

**10.01**  
Standard  
150 per pallet

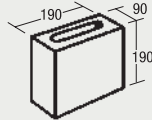

**10.02**  
Standard Half  
300 per pallet

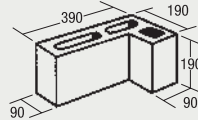

**10.03**  
Return Corner  
144 per pallet

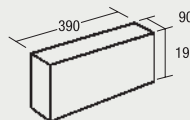

**10.17**  
Solid Block  
120 per pallet

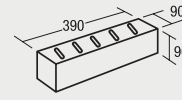

**H10.01**  
Standard Half High  
300 per pallet

### 15 SERIES

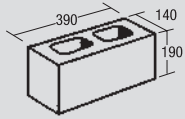

**15.04**  
Plain End  
120 per pallet

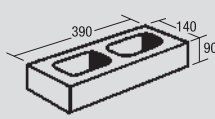

**H15.04**  
Standard Half High  
240 per pallet

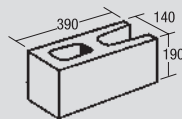

**15.05**  
Open End  
120 per pallet

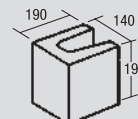

**15.12**  
Half Lintel  
240 per pallet

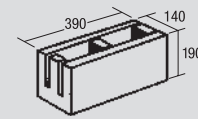

**15.14**  
Knock Out Bond  
Beam  
120 per pallet

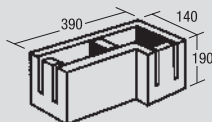

*Right Hand Shown*

**15.15**  
Corner Bond Beam  
Left or Right  
102 per pallet

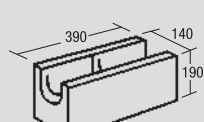

**15.16**  
Open End Bond Beam  
120 per pallet

#### RECOMMENDATIONS

We recommend that this product is installed by a Licensed Building Practitioner, qualified in Brick & Block Laying in accordance with NZS 4210. We recommend the use of Control Joints. Refer to our full technical data sheet for more information. Design DWG's are available on our website.

#### NOTE

Other Block types may be available as a 'Made to Order' product. A range of colours are available as a 'Made to Order' product. Colour and Texture may vary between block types. Concrete products may display 'efflorescence' (whitening) which is a natural occurrence. We have taken all possible steps to minimise this from occurring in our products.

## USEFUL ESTIMATING DATA FOR BOWERS HOLLOW MASONRY



#### Blockfill Volume

15 Series = 165 blocks/m<sup>3</sup>  
20 Series = 125 blocks/m<sup>3</sup>  
25 Series = 85 blocks/m<sup>3</sup>



#### Units per m<sup>2</sup>

15 Series = 12.5 units  
20 Series = 12.5 units  
25 Series = 12.5 units

Half High 15 Series = 25 units  
Half High 20 Series = 25 units  
Half High 25 Series = 25 units

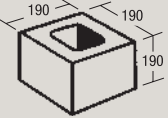
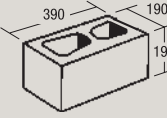
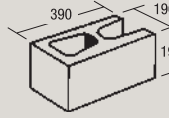
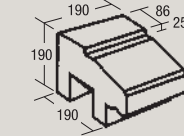
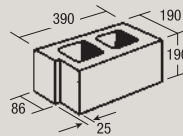
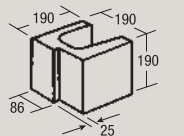
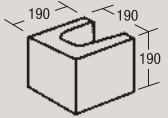
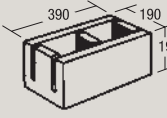
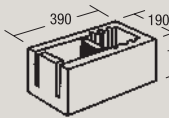
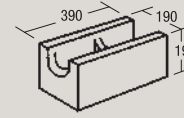
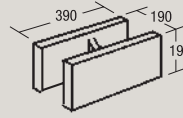
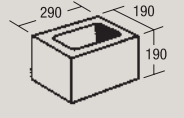
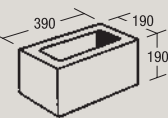
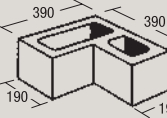
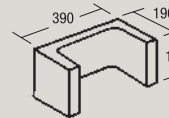
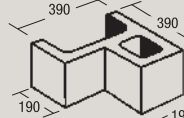
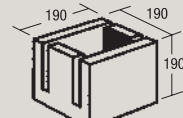
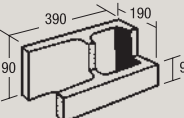
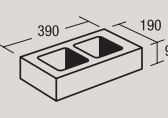
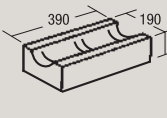
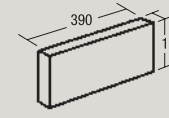

## 20 SERIES

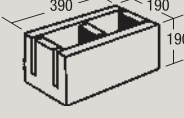
					
<b>20.02</b> Plain Half 180 per pallet	<b>20.04</b> Flush Ends 90 per pallet	<b>20.05</b> Open End 90 per pallet	<b>20.08</b> Sill 150 per pallet	<b>20.09</b> Rebate 90 per pallet	<b>20.11</b> Rebate Lintel 195 per pallet
					
<b>20.12</b> Plan Half Lintel 234 per pallet	<b>20.14</b> Knock Out Bond Beam 90 per pallet	<b>20.15</b> Corner Bond Beam 90 per pallet	<b>20.16</b> Open End Bond Beam 90 per pallet	<b>20.16H</b> Open Both End Bond Beam 90 per pallet	<b>20.19</b> Three Quarter 10 per pallet
					
<b>20.30</b> Pier 90 per pallet	<b>20.33</b> Pier 50 per pallet	<b>20.34</b> C-Type Pilaster 100 per pallet	<b>20.35</b> H-Type Pilaster 50 per pallet	<b>20.44</b> Half Knock Out Bond Beam 180 per pallet	<b>20.45</b> Header 120 per pallet
			<b>20 SERIES COLOURED MASONRY</b>   Midnight		
<b>H20.04</b> Standard Half High 180 per pallet	<b>H20.14</b> Half High Bond Beam 180 per pallet	<b>517</b> Capping Block 300 per pallet		<b>2014u</b> Universal Bond Beam 90 per pallet	

## 25 SERIES

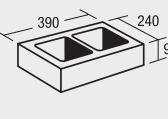
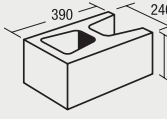
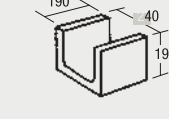
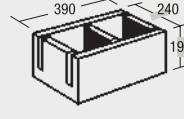
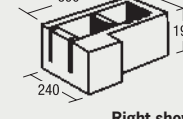
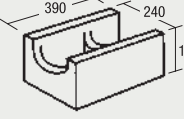
					
<b>H25.04</b> Standard Half High 156 per pallet	<b>25.05</b> Plain End 78 per pallet	<b>25.12</b> Lintel 192 per pallet	<b>25.14</b> Knock Out Bond Beam 78 per pallet	<b>25.15</b> Corner Bond Beam Left or Right 78 per pallet	<b>25.16</b> Open End Bond Beam 78 per pallet

# FAIR FACED BLOCKS

## EXPOSED BLOCK WORK

Check the block layer is a registered Licensed Building Practitioner (LBP). Ensure your block layer is aware you are after a 'Fair Face finish' and that the project is not going to be painted or plastered over.

Customer expectations for appearance and quality should be checked prior to commencement of the job. It is a good idea to build a sample panel of the blocks prior to starting the project for the client to inspect. Make them aware that they may get chipping, joint size variations to compensate the size tolerations of blocks and that mortar colours may bleed into the block. i.e. dark mortar against a light coloured block.

Stack Bonded block work will also enhance any chipping or variations.

Different block profiles will vary in texture and colour as they are not produced in the same batch. Limit the amount of block types used in a job to achieve a better finish. This may require the block layer having to do extra cutting on site. Allow for this in your pricing.

Be selective when laying the blocks - put stained, damaged or chipped blocks to one side and do not lay them in highly visible areas. i.e. near the front door.

Chips of varying sizes may be evident on the edges and corners of the blocks. Complete product breakage may also occur during cartage, especially on long distance haulage or during unloading. These are an unavoidable part of distributing and manufacturing any masonry product. Minor cracks and chips can occur but are not recognised as block defects.

The use of "raked" joints will emphasise chipping to the edges of the blocks. Concave or flush joints will tend to hide these minor chips. Please note that "raked" joints are also not recommended for external walls as the joint may retain water.

Any product which has been rejected by the customer or their layer due to chips or breakage will be the customer's responsibility. A wastage percentage should be applied to every project and typically an extra 10% should be ordered to compensate for this.

Chipping should be limited to 5% of a consignment containing less than 12.5mm in any dimension and any cracking to be less than 0.5mm in width and less than 25% of the nominal height of the unit.

Chips and imperfections should not be evident when viewed from a distance of not less than 6.1m of the constructed wall, under diffused light, as per ASTM C90, which has been adopted as the industry standard for viewing brick and block work.

Block work should be kept dry during the construction process and prior to sealing.

When placing the order, you must:

- Inform "Bowers Brothers" that this is a "Fair Face Job".
- Place the order for the "entire" job, not just a load at a time.
- Allow for extra time for the order to be selected.
- This will allow us to be able to select different block types from batches that have the best possible colour match, however, there is no guarantee.







# ON SITE HONING FINISH

Please make note of all aspects covered in Fair Face block work as these also apply to honed block work.

Honed masonry is from the standard range of 10, 15, 20 and 25 series hollow blocks. The block surfaces are ground back, removing 2mm – 3mm off the block face giving a smooth finish that reveals the aggregate. The results from the manufacturing process and delivery and may only become apparent after the honing process.

Hairline cracks, chips or other imperfections may be exposed after the honing process that were not evident during the construction of the wall. This is strictly an aesthetic issue which needs to be discussed with the client. Ways to rectify these should have been discussed prior to commencement of the honing and should be part of the honing contractors price. You should also allow for the block layer having to cut out and replace the face of a block in the event of the honing process exposing something that the honer cannot rectify. These costs should also be allowed for.

Only contractors who specialise in Honing on site should be used for this process. As masonry blocks are manufactured using natural products, some variation in the shade and aggregate density should be expected.



# SHOT BLASTED FINISH

Shot Blasted masonry is from the standard range of 10, 15, 20 and 25 series hollow blocks. The block surfaces are shot blasted, removing 2mm – 3mm off the block face giving a rough finish that reveals the aggregate.

Shot Blasting gives a similar appearance to Honed Blocks from a distance however it helps disguise chipping and joint size variations due to the rough texture.

Please make note of all aspects covered in Fair Faced and Honed block work as these may also apply to Shot Blasted block work.

Shot Blasting is a secondary process that is carried out on a “Made to order” basis and we do not accept returns on “Made to order” product.





# COLOURED MASONRY FINISH

It's important to note that when using coloured masonry blocks, you have the option to choose from three different finishes: Fair Face, Honed, or Shot Blasted. These finishes can significantly affect the appearance and texture of the blocks.

Coloured masonry blocks are typically manufactured on a "Made to Order" basis. This means that the blocks are produced specifically for your project, ensuring that you get the colour and finish you desire.

It's crucial to understand that the aspects covered in Fair Face block work also apply to coloured block work. Fair Face block work involves achieving a high-quality, smooth, and aesthetically pleasing finish on the visible surfaces of the masonry. This includes attention to alignment, mortar joints, and surface imperfections.

Different batches or types of coloured blocks may exhibit variations in shade and texture. To maintain consistency and achieve the desired appearance in your project, it's strongly recommended to limit the number of block types used. Consistency in block selection can help ensure a uniform finish.

To navigate the selection and use of coloured masonry blocks effectively, it's advisable to speak with your local Bowers representative. They can provide guidance on the available options, assist in choosing the right block type, and offer insights into best practices for installation and finishing.

When working with coloured masonry blocks, consider the finish options available, order blocks on a made-to-order basis, pay attention to Fair Face block work principles, limit block types for consistency, and seek guidance from Bowers to ensure a successful and visually appealing construction project.



# COLOUR MATCHED OXIDE MORTAR DROP PACKS

## FOR COLOURED MASONRY



Bowers Midnight Mortar Drop Packs are an innovative product that involves incorporating dissolvable bags with engineered colours into bagged structural mortar for construction purposes.

This inventive approach offers simplicity and environmental benefits. By using dissolvable bags containing engineered colours made from high-quality recycled materials, you're able to achieve natural, colour-fast, and durable results while minimizing environmental impact. This creative solution addresses both practical construction needs and sustainability considerations.

If you have any specific questions or if you'd like to discuss more details about this product, feel free to contact Bowers.





## USEFUL ESTIMATING DATA FOR BOWERS HOLLOW MASONRY

### Blockfill Volume

15 Series = 165 blocks/m<sup>3</sup>

20 Series = 125 blocks/m<sup>3</sup>

25 Series = 85 blocks/m<sup>3</sup>

### Units per square metre

15 Series = 12.5 units

20 Series = 12.5 units

25 Series = 12.5 units

Half High 15 Series = 25 units

Half High 20 Series = 25 units

Half High 25 Series = 25 units

## RECOMMENDATIONS

We recommend that this product is installed by a Licensed Building Practitioner, qualified in Brick & Block Laying in accordance with NZS 4210. We recommend the use of Control Joints.

Refer to our full technical data sheet for more information.

Design DWG's are available on our website.



 0800 207 374

 [sales@bowersbrothers.co.nz](mailto:sales@bowersbrothers.co.nz)

 [www.bowersbrothers.co.nz](http://www.bowersbrothers.co.nz)

**Bowers Brothers Concrete Ltd**

51 Lorne Street, Morrinsville, New Zealand 3300

**NZ MADE MASONRY**

**Blocks | Bricks | Paving | Retaining**

